

Protection against lightning effects



07

POWER GUIDE 2009 / BOOK 07

INTRO

Lightning is one of those natural events which catches people's imagination with its obvious violence and the destructive power attributed to it. Thunder and lightning was believed to be the expression of the wrath of the gods. Lightning fascinates and frightens us. The considerable damage it causes to property and its unfortunate victims plainly demonstrate that the imaginary is based on a phenomenon that is very real and can be fairly well explained, but cannot be combated. Only modest attempts can be made to control its effects and the consequences.

Lightning can be likened to a disruptive electrical discharge due to the dielectric breakdown of the air between the clouds or between the clouds and the ground. Certain clouds (cumulo-nimbus) create meteorological conditions that are favourable to the accumulation of electrostatic charges.

Breakdown, which is visible in the form of the lightning flash, itself has a very complex phenomenology (precursor, leader stroke, return discharge, etc.). It is accompanied by a sound wave, thunder, caused by the sudden expansion of the air which is overheated by the electric arc.

When lightning reaches the earth, it generally does so directly on natural elements (trees, hills, water, etc.) but also occasionally on structures, buildings, pylons and other man-made structures.

A distinction that leads to the division into two separate types of effect:

- Those described as "direct" which are due to the circulation of the intense current (several tens of thousands of amperes) which heats materials and causes considerable damage (calcination, fire, dislocation or even collapse)
- Associated, "indirect" effects which produce overvoltages by conduction, induction or increasing the earth potential.

Protection must be provided against these indirect effects in electrical installations which, besides their sensitive, not to say strategic, role have also become more fragile due to their increasing numbers, size and the corollary use of electronics.

The main function of voltage surge protectors is to provide protection against the indirect effects of lightning. It is important to note that they are also involved in protecting equipment against internal transient overvoltages due to the switching of motors and other inductive loads, and more generally to breaking operations on the installation. These events are less destructive than lightning, but occur more frequently.

Lightning and its effects

| | |
|--|----|
| The mechanisms of lightning | 02 |
| The effects of lightning | 04 |
| 1. Direct effects (strikes on structures) | 04 |
| 2. Indirect effects (network overvoltages) | 04 |

Protection against the effects of lightning

| | |
|--|----|
| Risk analysis: numerous tools available | 08 |
| Protection of structures (external protection) | 09 |
| 1. Protection systems (lightning conductors) | 09 |
| 2. The electrogeometric model | 10 |
| 3. Capture surface areas | 11 |
| 4. Downconductors | 12 |
| 5. Earthing system | 13 |
| Protection of networks and internal equipment | 14 |
| 1. Active and passive protection of the installation | 14 |
| 2. Lightning strike withstand of equipment | 15 |
| 3. Passive protection | 16 |
| 4. General architecture of the bonding system | 18 |

Voltage surge protectors

| | |
|--|----|
| Operating principle | 20 |
| Main technologies and characteristics | 21 |
| 1. Air spark gap, surface discharge or gas discharge tube voltage surge protectors | 21 |
| 2. Voltage surge protectors with varistor | 21 |
| 3. Voltage surge protectors with silicon components (Zener diodes, thyristor, etc.) | 21 |
| 4. Main characteristics | 22 |
| Protection principle | 23 |
| 1. Protection modes | 23 |
| 2. Cascaded protection | 24 |
| 3. Location of voltage surge protectors | 25 |
| 4. Protected lengths | 26 |
| Installing voltage surge protectors | 27 |
| 1. Connecting voltage surge protectors | 27 |
| 2. End of life protection of voltage surge protectors | 30 |
| 3. Coordinating voltage surge protectors | 31 |
| Selecting voltage surge protectors | 32 |
| The Legrand range of voltage surge protectors | 36 |
| 1. Class I voltage surge protectors | 36 |
| 2. Class II voltage surge protectors | 37 |
| Characteristics of Legrand voltage surge protectors | 38 |
| 1. Modular voltage surge protectors | 38 |
| 2. Proximity voltage surge protectors | 39 |
| Protection of telephone lines | 40 |

Lightning and its effects

Lightning can cause considerable damage. It is a hazard that must be taken into account for installations and electrical equipment. A good knowledge of this natural phenomenon and its effects is essential for assessing the risk and choosing the best protection methods. The approach presented in the second part provides a simple definition of the solutions appropriate for each type of installation in accordance with good professional practice.

THE MECHANISMS OF LIGHTNING

The mechanisms of lightning are very complex, but can be explained in simple terms as involving a very high energy electrical discharge caused by the difference in potential between clouds or between the clouds and the ground. Lightning currents are more than 20 kA in 80% of cases and can reach values in the region of 200 kA (or even more) with rise times of a few microseconds (source CIGRE – Electra no. 41 and 69).

In France, as in Italy or Spain, around 2 million lightning strikes hit the ground every year. Throughout the world, there are some 5000 storms/day or 1000 lightning strikes per second. Tens of thousands of buildings, telephone and electric lines are put out of service, with lightning accounting for more than 25%

of all damage to electrical installations and equipment (up to 40% in some countries). Thousands of animals and several dozen people are also victims of lightning. The risk of storms is determined locally by the keraunic level N_k or T_d (number of days per year that thunder is heard). Installations in mountainous regions are the most exposed, as are those located close to bodies of water or at the end of lines. In practice, administrative maps showing the lightning density N_g are used. These are drawn up based on observations carried out by the monitoring networks (Météorage network in France and Europe) and give the number of ground lightning strikes per year per km^2 (lightning strike density) N_g , where $N_k = 10 N_g$ (IEC 60364-4-443).

Keraunic levels (N_k) in the world

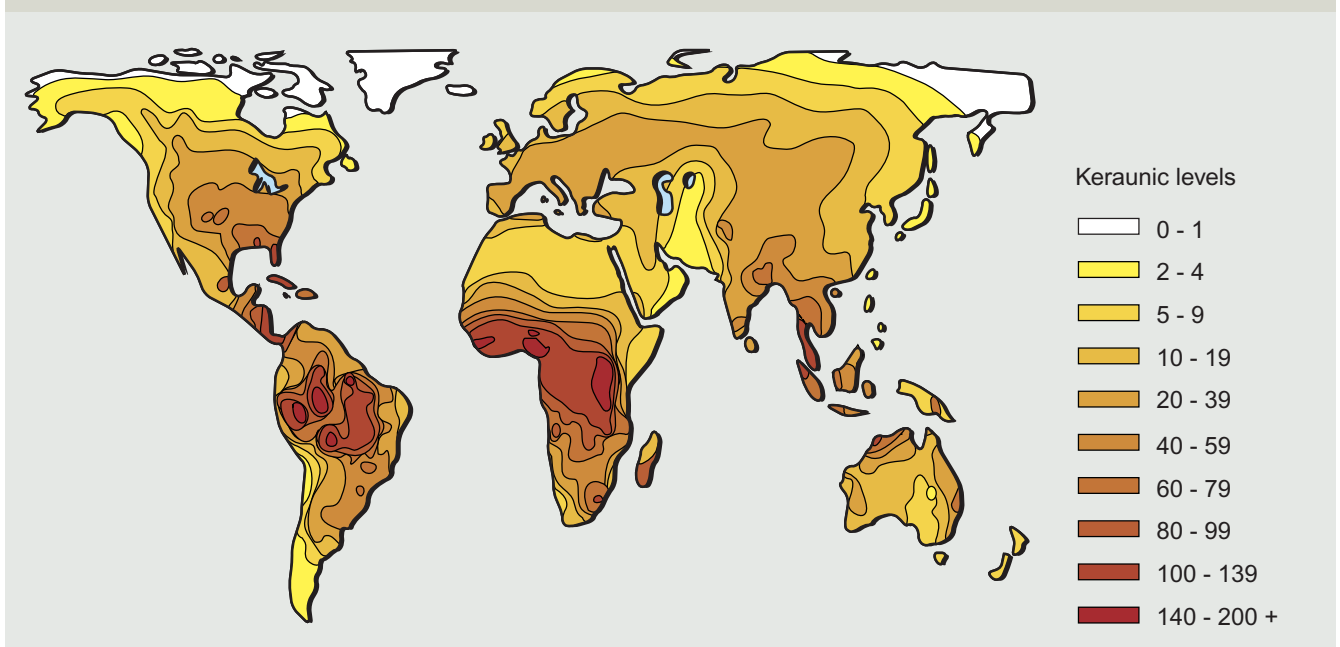



The different types of ground lightning strike

Depending on the direction in which the charge develops (cloud-to-ground or ground-to-cloud) and whether the charge is negative or positive, there are four different types of ground lightning strike.

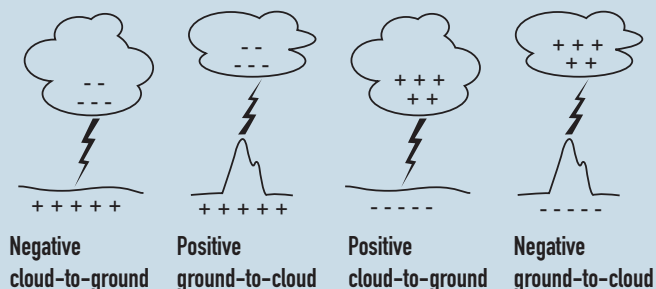

In Northern European climates, negative cloud-to-ground lightning strikes are the most common in lowland areas. The discharge current varies from a few tens of kA to a hundred or so kA. A “precursor” traces a conductive channel descending from the cloud to the ground and the lightning discharges as “feedback” from the ground to the cloud.

When the precursor is ascending, the lightning strike is said to be from ground-to-cloud. Positive ground-to-cloud lightning strikes, which occur more frequently in winter, are more rare (10 %), and are also more violent (several hundred kA). They develop starting from a natural or artificial prominence.



Electrical model of an atmospheric discharge

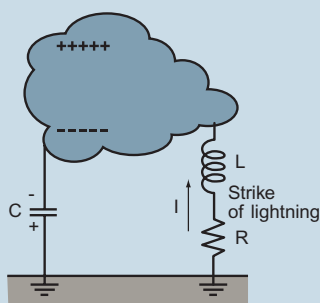

An initial discharge (precursor) leaving the cloud travels towards the ground in a random way. Near this, it meets an “ascending leader” which develops from a point connected to earth (tree, building, lightning conductor or the ground itself). When the precursor and leader meet, the lightning strike proper occurs with emission of light (lightning flash) and sound (thunder), and the discharge of an intense current.

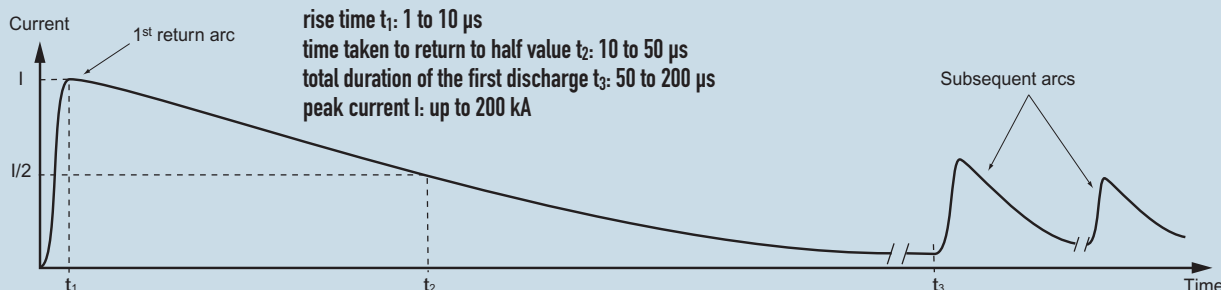

rise time t_1 : 1 to 10 μ s
 time taken to return to half value t_2 : 10 to 50 μ s
 total duration of the first discharge t_3 : 50 to 200 μ s
 peak current I : up to 200 kA

Typical shape of the atmospheric discharge current of a negative cloud-to-ground lightning strike. There are generally several feedback arcs (subsequent arcs) which may occur one after the other.

Lightning and its effects (continued)

THE EFFECTS OF LIGHTNING

The effects of lightning are commonly divided into direct and indirect effects.

1 DIRECT EFFECTS (strikes on structures)

At the point of the strike, lightning generates:

- Direct thermal effects (melting, fire) caused by the electric arc
- Thermal and electrodynamic effects induced by circulation of the lightning current
- Blast effects (shock wave and blast air) produced by heat and the expansion of the air.

Protection against the direct effects of lightning is based on catching the current and discharging it to earth (lightning conductor, catcher rods, etc).



2 INDIRECT EFFECTS (network overvoltages)

Overvoltages due to lightning can reach the installation by three means of access:

- By conduction following direct lightning strikes on lines (power, telecommunications, TV, etc.) entering or exiting buildings

- By feedback from earth via the earthing system, the protective conductors and the exposed conductive parts of equipment
 - By induction in the installation's conductive elements (structure of the building, etc.) and internal lines (power, telecommunications, etc.)
- The effects of lightning can be felt by induction within a 1 km radius, and by conduction (feedback from earth and strikes on lines) within a radius of more than 10 km.

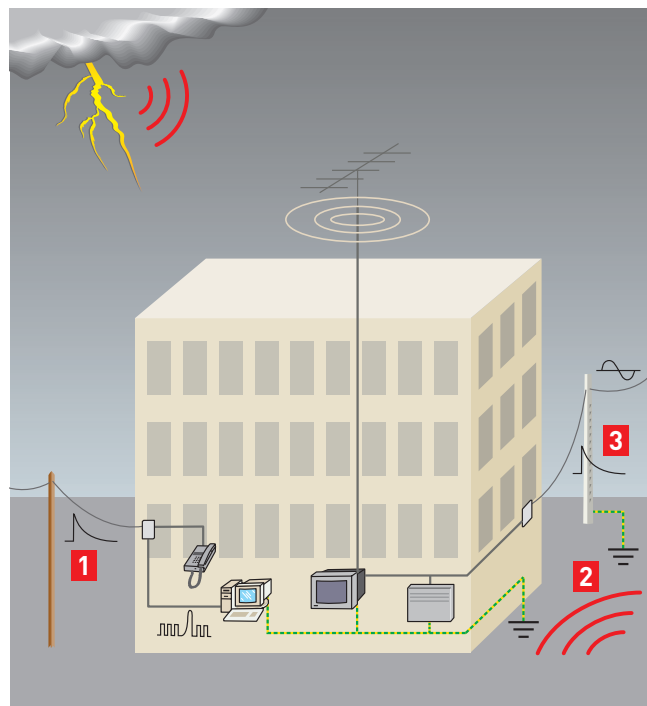

Statistically, damage to electrical installations and equipment is mainly the result of the indirect effects of lightning strikes and overvoltages from operations, against which it is important to provide protection by installing voltage surge protectors.

Simplified electrical models of overvoltages caused by lightning

1 Overvoltages due to strikes on lines

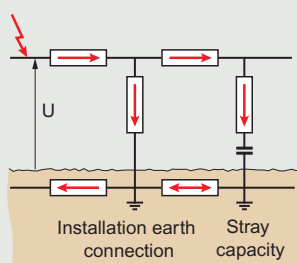

2 Overvoltages caused by feedback from earth (see p. 06)

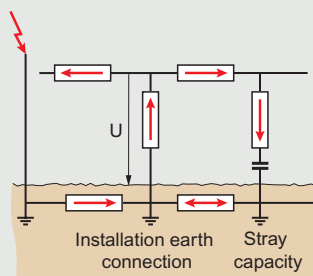

3 Overvoltages caused by electromagnetic induction (see p. 07)

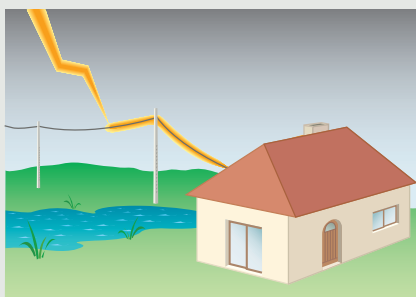
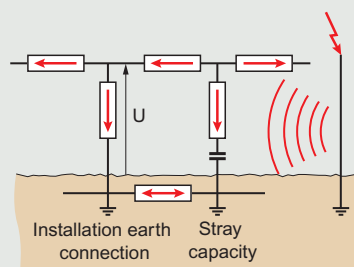

Lightning strikes on overhead lines lead to overvoltages of several thousand volts spreading onto the HV and LV networks.

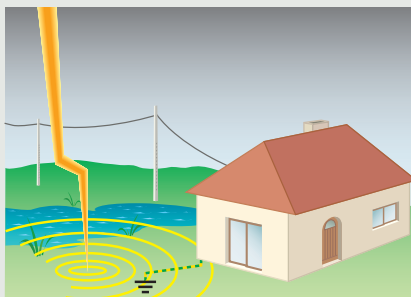

A lightning strike on the ground causes an increase in the earth potential, which can spread to the installation (fed back from earth).

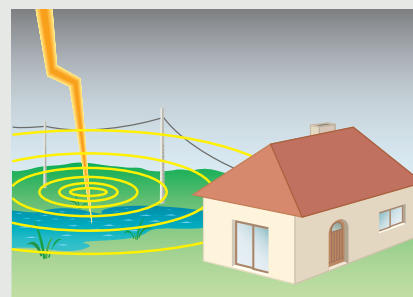

Associated with the lightning discharge is an electromagnetic field with a wide frequency spectrum which, as it connects to the loops in the installation, will give rise to destructive induced currents.



Standard IEC 60364-5-51 defines three levels of lightning risk (AQ):

AQ1: $Nk \leq 25$

AQ2: $Nk > 25$

AQ3: risk of direct lightning strike on structures

As a general rule, it is advisable to protect equipment using voltage surge protectors in AQ2 areas (compulsory protection if power supply via overhead lines) and using voltage surge protectors and lightning conductors in AQ3 areas.

Lightning and its effects (continued)



Overvoltages caused by feedback from earth

The lightning current that falls on a lightning conductor causes an increase in the earth potential of the installation, which will cause an overvoltage between the earthing system (foundations) and the internal lines (power, telephone, TV) within the installation. This overvoltage spreads to neighbouring installations via the distribution network. When a lightning strike hits the ground or an item near the building (prominence, tree, post, etc.) directly, there is a similar increase in the earth potential causing overvoltages in installations near the strike, via their earthing electrodes, within a radius of approximately 50 m.

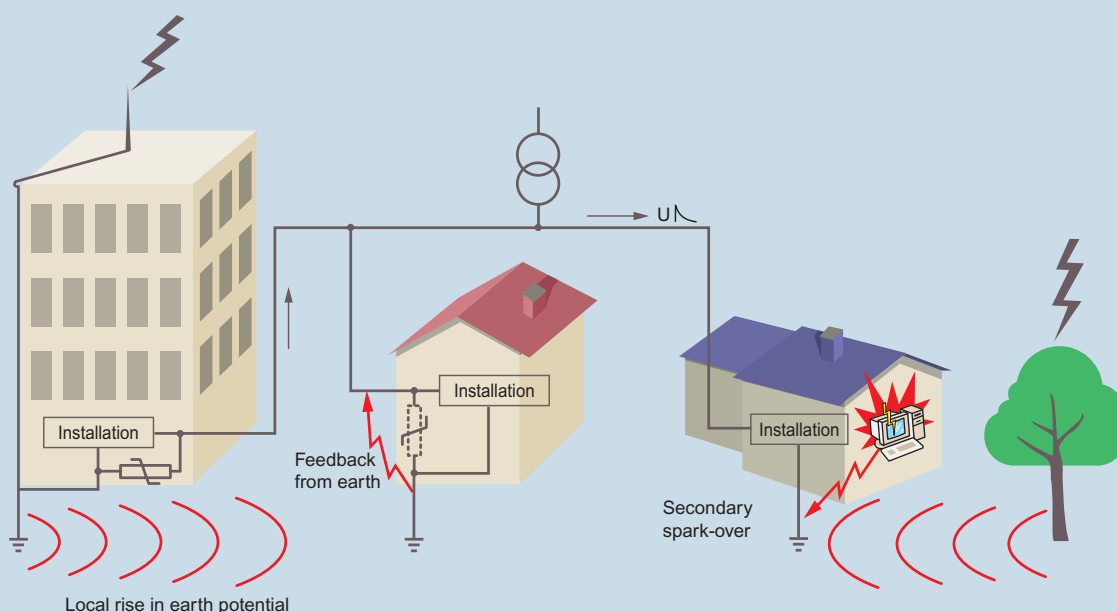

Close to the lightning strike, the overvoltage, said to be "fed back from earth", spreads (is fed back) from the earth to the network via the installation. In the case of lightning strikes on a lightning conductor or in the immediate vicinity of the installation, the effects are extremely destructive if there are no voltage surge protectors (breakdown and destruction of equipment connected to the network). The overvoltage U spreads via the network to the neighbouring installations and can then cause destructive secondary sparkovers between the live conductors and the exposed conductive parts of equipment in those neighbouring installations whose earth is referenced to a different potential. This type of phenomenon is often observed in installations close to churches or very tall buildings. To limit the consequences of such phenomena, which are always difficult to foresee, you should:

- Equip all installations supplied by the same LV network with voltage surge protectors
- Make all the bonding systems equipotential via interconnected earthing electrodes. This solution is possible on groups of buildings (industrial sites), but is unrealistic in the home.

It should be noted that the neutral conductor, when properly earthed, provides a certain equipotentiality. In TT earthing systems, the earthing electrodes which are separate for the network and the installation impair this equipotentiality and are sources of voltage differences. In this respect, the TN earthing system, which has only one earthing electrode for the power supply and the installation, is more favourable.

It must also be remembered that although they are naturally protected against direct effects, underground distribution networks can also induce feedback from earth.



Overvoltages induced by electromagnetic induction

The lightning discharge current, whether by direct strike or carried by a lightning conductor downconductor, generates a field whose electrical and magnetic components reach considerable values: several kV/m and several tens of microtesla (μT).

This radiation is received by all the conductors, forming a more or less appropriate aerial, which becomes the focus of the induced currents. It is particularly on the conductors which make up loops with large surface areas that the effect of magnetic induction (field H) is predominant.

The field generated by the current i (several kA) in the lightning conductor downconductor connects to the loop formed by the conductors in the building, generating a voltage U of several kV.

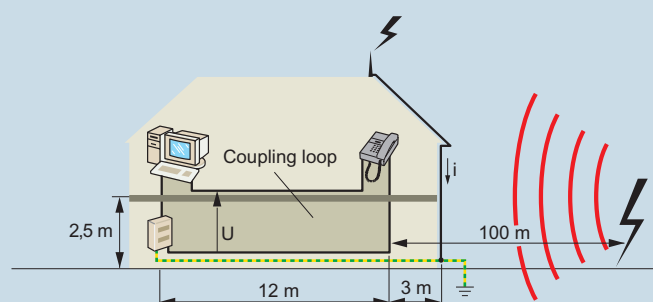

This phenomenon also occurs, though to a lesser degree, when there is a strike some distance away, even as far as several hundred metres.

For example, a 10 kA lightning current 100 m away will generate a 600 V overvoltage in a 30 m^2 loop.

The same lightning current in the lightning conductor downconductor (located 3 m away) will generate an overvoltage of more than 15 kV.

In the first case, the overvoltage can be absorbed without too much damage, whereas in the second it will certainly be destructive.

This also illustrates how the presence of a lightning conductor can only be considered if voltage surge protectors are installed in the installation.

Inductive coupling of a single conductor on a loop :

$U = M \times \frac{di}{dt}$ where M is a coefficient characterising the coupling according to distances L_1 and L_2 , the loop surface area and the magnetic permeability of the environment.

In practice, it is assumed that the loop plane is at right-angles to the current i (therefore $L_1 = L_2$) and that the distance is greater than the size of the loop.

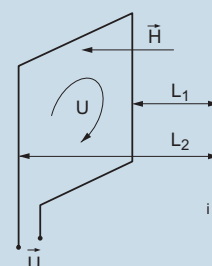

Lightning protection installations never provide total protection of people and property. The measures taken are intended to statistically reduce the risks with regard to the elements considered, but it must be remembered that they will inevitably be partly based on empiricism.

Protection against the effects of lightning

Lightning protection systems, essentially lightning conductors (protection of structures) and voltage surge protectors (protection against overvoltages), offer effective protection if they are defined and installed with care.

RISK ANALYSIS: NUMEROUS TOOLS AVAILABLE

Firstly, an exhaustive analysis of the risk of lightning is necessary, taking numerous factors into consideration: local meteorological risks, specific geographical features of the location, nature of the structure or site to be protected, its incoming networks (electrical, telephone networks, etc.), type of structure and scale of the buildings (industry, airports, etc.), activity (installations classified for environmental protection, public buildings) and associated risks (environmental, human, financial, etc.), fragility of equipment (computing, electronic, etc.), strategic level of the installations (public services, transport, civil or military safety, etc.) and if possible local storm history with damage caused by lightning. All this information must be considered

with regard to the reasonably acceptable failure rate, its cost and its possible consequences. There are various risk analysis methods for this. Their application may be compulsory, depending on the national regulations and the type of installation. The protection of installations and the electrical or electronic equipment within them is based on the application of national installation standards (equivalent to IEC 60364) and guides specifically about voltage surge protectors (equivalent to IEC 61643-12). The protection of the structures will be based on the application of standards concerning protection against lightning (equivalent to IEC 62305).



Standard IEC (EN) 62305 or equivalent national standards

These standards describe the general principles of overall protection of structures and internal equipment against lightning (part 1).

The following parts give information specific to the assessment of the risk of lightning taking into account concepts of foreseeable and acceptable damage and economic requirements (part 2), protection against physical damage connected with the structures (part 3) and damage to the electrical or electronic equipment within the structure (part 4).

Depending on national regulations, the application of these standards can be compulsory for the protection of sensitive sites (public services, transport, civil or military safety, etc.) or high-risk sites (risks for the environment and for people, etc.). They are often quoted as references for carrying out studies of complex installations (industry, airports, etc.). However, in the absence of any national requirements stipulating their application, protection against overvoltages can be implemented in accordance with standard IEC 61643-12 or national equivalents.

Standard IEC (CLC/TS) 61643-12, 61643-22

An addition to IEC 62305, this standard specifies the rules to be followed to protect an electrical installation (IEC 61643-22: communication networks) against overvoltages, from the analysis of the risk and the design of the protection system, through to its totally safe installation.

Standard IEC (Europe: HD) 60364

Apart from any specific local requirements, the provisions of parts 443 and 534 (HD 60364 § 534: to be published shortly) are contained in the national installation standards. They define the conditions under which voltage surge protectors are required at the origin of the installation for protection against the risks of overvoltages:

- Installations with overhead power supplies in AQ2 areas ($N_k > 25$). Also required for installations with medical services or equipped with safety systems for people and property.
- Class I voltage surge protector for installations equipped with lightning conductors.

Higher requirement levels (number of voltage surge protectors, discharge capacity, etc.) can be defined based on an analysis of the risk, in particular for installations that are strategic or cover a large area (public services, industries, commercial or office complexes, public places, etc.) in accordance with standard IEC 61643-12 or IEC 62305 (see p. 32: Legend recommendations).

PROTECTION OF STRUCTURES (EXTERNAL PROTECTION)

1 PROTECTION SYSTEMS (lightning conductors)

The purpose of these is to protect structures against direct lightning strikes. By catching the lightning and running the discharge current to earth, they avoid damage connected with the lightning strike itself and circulation of the associated current.

Lightning conductors are divided into four categories.

1.1. Single rod lightning conductors (Franklin rods)

These consist of one or more tips, depending on the size of the structure and the downconductors. They are connected either directly to the earthing electrode of the installation (foundation), or, depending on the type of protection and national work practices, to a special earthing electrode (lightning conductor earthing electrode) which is itself connected to the earth of the installation.

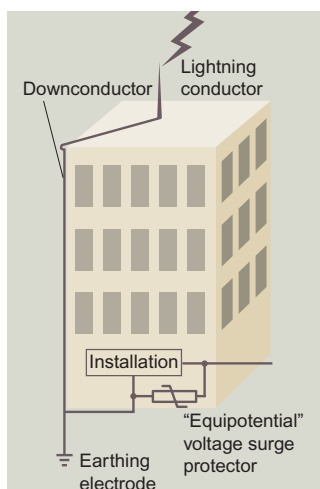

1.2. Lightning conductors with sparkover device

These are a development of the single rod. They are equipped with a sparkover device which creates an electric field at the tip, helping to catch the lightning and improving their effectiveness. Several lightning conductors can be installed on the same structure. They must be interconnected as well as their earthing electrodes.

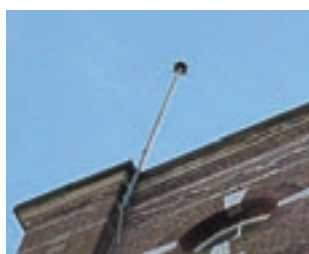

For buildings more than 60 m high which are protected by single rod lightning conductors or lightning conductors with sparkover devices, the protection system is completed by a metal ring at the top to avoid the risk of lateral lightning strikes.

1.3. Lightning conductors with meshed cage

The meshed cage consists of a network of conductors arranged around the outside of the building so that its whole volume is circumscribed. Catcher rods (0.3 to 0.5 m high) are added to this network at regular intervals on projecting points (rooftops, guttering, etc.). All the conductors are interconnected to the earthing system (foundation) by downconductors.

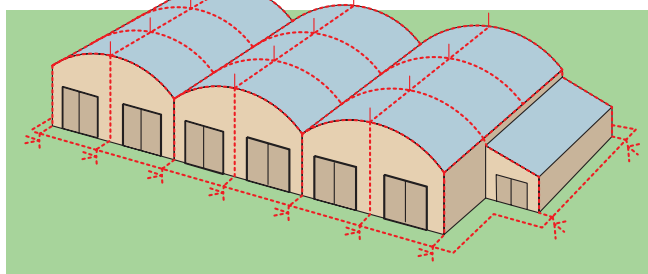

^ Lightning conductors with a meshed cage complete the meshing systems to protect buildings against the radiated electromagnetic fields to which they must be interconnected

1.4. Lightning conductors with earthing wires

This system is used above certain buildings, outdoor storage areas, electric lines (overhead earth wire), etc. The electrogeometric model of the sphere applies to these.



Protection against the effects of lightning (continued)



As the the installation of lightning conductors considerably increases the risk of overvoltages, voltage surge protectors must also be used. According to standard IEC 60364, a class I voltage surge protector (min. Imp 12.5 kA - waveform 10/350) is required at the origin of the installation. This value can be specified by a risk analysis if necessary (IEC 62305 or similar). For apartment blocks, it is also recommended that a class II voltage surge protector be installed at the origin of each private installation (in accordance with national rules - compulsory in France according to standard NF C 15-100 when the class I voltage surge protector cannot be installed at the origin of the apartment block installation).

2 THE ELECTROGEOMETRIC MODEL

The choice and positioning of lightning capture devices requires a specific study of each site, the objective being to ensure that the lightning will preferably “fall” at one of the predefined points (lightning conductors) and not some other part of the building. There are various methods for doing this, depending on the type of capture device (lightning conductor) and national work practices (see IEC 62305). One of these, called the “electrogeometric model” (or imaginary sphere model) method, defines the spherical volume that is theoretically protected by a lightning conductor according to the intensity of the discharge current of the first arc. The higher this current, the higher the probability of capture and the wider the protected area.

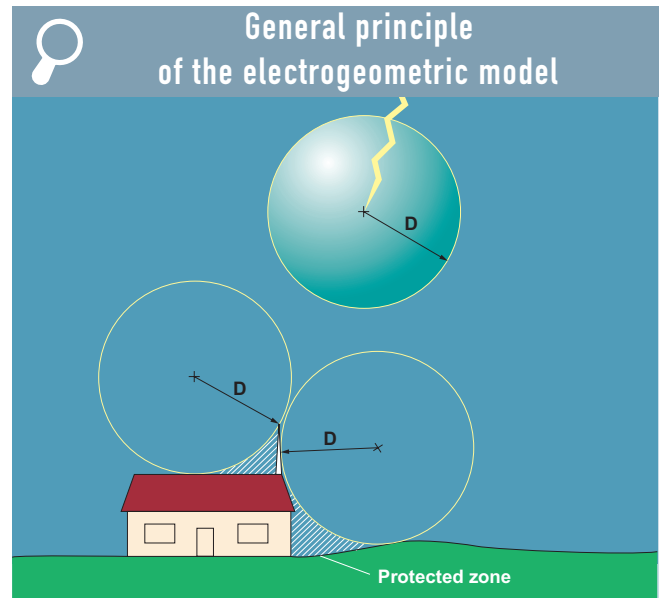

The tip of the leader stroke (or precursor) is deemed to represent the centre of an imaginary sphere, with a radius D. This sphere follows the random path of the leader stroke. The first element to come into contact with this sphere will determine the point at which the lightning will strike: a tree, a roof, the ground or a lightning conductor, if there is one. Beyond the points of tangency of this sphere, protection is no longer provided by the lightning conductor.

The theoretical radius (D) of the sphere is defined by the relationship: $D = 10 \times I^{2/3}$, where D is in metres and I is in kA.

| | | | | | | |
|--------|----|----|----|----|-----|-----|
| D (m) | 15 | 29 | 46 | 96 | 135 | 215 |
| I (kA) | 2 | 5 | 10 | 30 | 50 | 100 |

For optimum protection incorporating the probable lowest lightning current values (protection level I), a 20 m (I = 2.8 kA) sphere must be considered.



Protection levels (IEC 62305)

The model must be adapted according to the type of protection device (single rod lightning conductor, meshed cage, earthing wires) and structure to be protected. Standard IEC 62305 defines protection volumes according to four protection levels based on the probability of capture:

| Level | I | II | III | IV |
|-----------------------------|----|----|-----|----|
| Probability of capture (%) | 99 | 97 | 91 | 84 |
| Min. capture current (kA) | 3 | 5 | 10 | 16 |
| Max. sparkover distance (m) | 20 | 30 | 45 | 60 |

3 CAPTURE SURFACE AREAS

When the site to be protected consists of several buildings or extends beyond the range of a single capture device (lightning conductor), a protection plan must be drawn up for the area, juxtaposing the different theoretical capture surface areas. It is always difficult to achieve total coverage of a site when it is made up of structures of different heights.

Superimposing the protection plan over the layout of the area makes it possible to see areas that are not covered, but above all it must assist in-depth consideration taking account of:

- The probability of lightning strikes by determining the main strike points (towers, chimneys, antennae, lamp posts, masts, etc.)
- The sensitivity of the equipment housed in the buildings (communication and computer equipment, PLCs, etc.)
- The potential risk linked to the business or the types of material stored (fire, explosion, etc.)

It must also be remembered that the numerous links

between the buildings (computer networks, remote monitoring, communications, alarms and power) can create interference as a result of the effect of the lightning's electromagnetic field or that of the voltage gradient generated in the ground.

There are two ways in which these links can be protected:

- Shielding or use of Faraday cages which will, as well as protecting against these fields, primarily maintain the equipotentiality of the link (adjacent earthing conductor, twisting, conductor screen, etc.)
- Galvanic decoupling, which will separate buildings electrically (optocouplers, fibre optics, isolation transformers, etc).



The protection plan must take the buildings and structures to be protected against direct lightning strikes into consideration, but it must also take into account elements or non-built areas for which lightning strikes may cause destructive effects.

Example of a protection plan

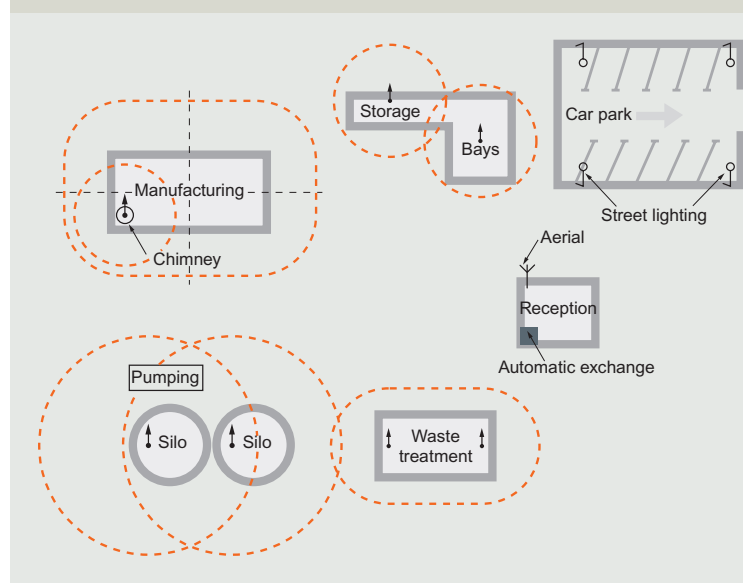

On this (imaginary) site we can see that the sensitive areas: manufacturing, storage, processing etc., have been protected effectively by lightning conductors or by a meshed cage, but that two areas are not protected, as they are considered to be low-risk: reception area and car park.

Further consideration shows that the lamp posts lighting the car park could be struck by lightning and transmit the lightning strike to the installation, and that the reception area which houses the telephone switchboard and the paging aerial (beep) represents an area which is both vulnerable and sensitive.

The pumping station is theoretically protected by the silo lightning conductors which are much higher. A situation which must not however allow us to forget that in this case a sideways lightning strike is possible.

Protection against the effects of lightning (continued)

4 DOWNCONDUCTORS

These provide the link between the lightning conductor itself (rod, cage, wire) and the earthing electrode. They are subjected to intense currents and must therefore be of an adequate cross-section (min. 50 mm² copper), flat (HF current), firmly fixed and follow the shortest possible route. They must have no rises or sharp angles. The conductors can be fitted with lightning strike counters.



It is advisable to increase the number of downconductors in order to reduce the currents in each one and the associated thermal, electrodynamic and inductive effects. Downconductors must end in a meshed, equipotential earth circuit.

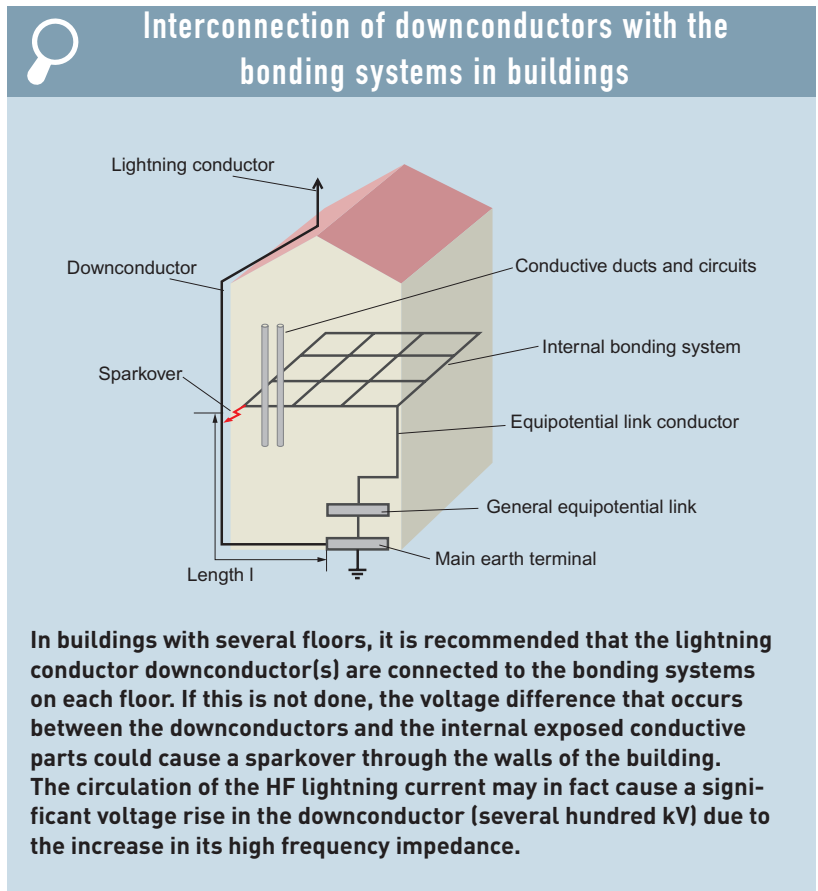

The consequences in the installation of the effects caused by circulation of the lightning current in the downconductors can be minimised by:

- Increasing the number of downconductors in order to divide the current and limit the effects caused
- Ensuring that the downconductors are interconnected with the bonding systems on all floors in the building
- Creating equipotential bonding systems incorporating all conductive elements, including those that are inaccessible: fluid pipes, protection circuits, reinforcements in concrete, metal frames, etc.
- Avoiding placing downconductors near sensitive areas or equipment (computing, telecommunications, etc.).



^ Lightning conductor earthing electrode

5 EARTHING SYSTEM

This is an essential element in protection against lightning: all the exposed conductive parts, which are themselves interconnected, must be connected, and the system must be capable of discharging the lightning current, avoiding a voltage rise in the earthing system itself and the surrounding ground.

Although it must be low enough ($< 10 \Omega$), the low frequency resistance value of the earthing electrode is less important than its shape and size as far as the discharge of the high frequency lightning current is concerned.

As a general rule, each downconductor must end in an earthing electrode which can consist of conductors (at least three) in a crow's foot layout buried at least 0.5 m deep, or earth rods, preferably in a triangular layout. In addition, IEC 62305 implies that the lightning conductor downconductors should be interconnected with the bonding system with the main equipotential

link (see diagram page 19).

When possible, it is always advisable to increase the number of downconductors and linking points (each floor), and thus to increase the overall scale of the equipotential bonding system. At the same time as this, the earthing system must of course be capable of discharging the lightning currents in order to limit the voltage rise of the bonding system as much as possible.

When the equipment to be protected is particularly sensitive (electronic with 0 V referenced to the bonding network, telecommunications, computing shielding, etc.), or when it is not possible to establish an effective high frequency earthing electrode (for example, rocky ground) or if the scale of the installation is such that there are numerous voltage feedback points (see diagram page 19), additional measures must be taken to provide protection against a high frequency voltage rise in the bonding system involving all circuits (in particular protection circuits: green yellow) interconnected with it.

Additional voltage surge protectors (class II) must be installed in the various secondary distribution panels and terminal distribution panels. Caution, these voltage surge protectors do not take the place of Class I voltage surge protectors, which are still required at the origin of the installation when there is a lightning conductor.



There must only be one earthing system. Separate, independent circuits (power, computers, electronic, communications) should be prohibited, but this does not exclude multiple earthing electrodes (electrodes) if they are all interconnected.



Impedance of earthing electrodes in high frequency systems

Earthing electrodes are generally designed to discharge low frequency fault currents. The resistance of the buried conductors, even if they are very long, is negligible in comparison with the resistance of the earthing electrode itself (a few milliohms as against a few ohms).

When there is a lightning strike, the current to be discharged is high frequency and the impedance of the earthing electrode then has an overriding inductive component. To limit this effect, the geometry of the earthing electrode must be adapted. The most commonly used layout is the crow's foot, but others may be preferred in ground with a low level of conductivity (plates). As for downconductors, links and connections must be made using flat conductors.

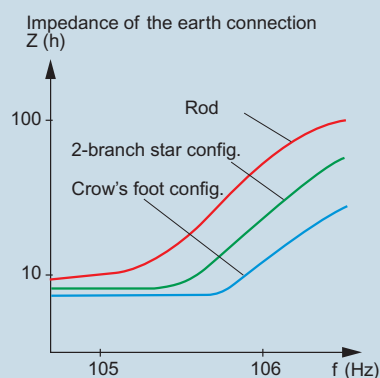

Protection against the effects of lightning (continued)

PROTECTION OF NETWORKS AND INTERNAL EQUIPMENT

1 ACTIVE AND PASSIVE PROTECTION OF THE INSTALLATION

The most commonly used protection devices such as fuses and circuit breakers are too slow in relation to the phenomenon of lightning and can in no way protect electrical or electronic equipment from overvoltages caused by lightning. Voltage surge protectors are necessary for this. Voltage surge protectors provide active protection of the installation. But they are only fully effective when installed carefully and correctly: choice of model, positioning, connection, etc.

In addition to this initial requirement, other criteria connected with physical characteristics of the installation (scale, equipotentiality, earthing system, separation of circuits, etc.) are also determining factors. They are grouped together under the term passive protection (see page 17).

Voltage surge protectors are also involved in protecting equipment.

- Against the risks of overvoltages from operations, that may occur statistically more often than overvoltages caused by lightning. Although their energy level is much lower, these overvoltages can also damage a large amount of equipment.

- Against electromagnetic interference up to frequencies in the region of several hundred kilohertz, such as interference caused by frequent starting of inductive or capacitive loads, or even the operating modes of some devices (repetitive starting of welding stations, high-pressure washers, contactors, radiators, air conditioning units, heaters, etc.). Although their energy level is low, these types of overvoltage can also cause accelerated ageing of very sensitive equipment (computers, modems, TVs, HiFi systems, etc.). However, the purpose of voltage surge protectors is not to:

- Protect equipment against high-frequency interference, for which filters must be used.
- Protect an installation against the risks of temporary overvoltages due to faults on the high or low voltage supply, such as neutral breaks.

Protection against these transient overvoltages

consists of preventing the interference-bearing, or even destructive, energy from reaching devices and equipment. Like the protection of structures, the basic operating principle of voltage surge protectors consists of giving the current a special route to ensure it discharges to earth. However, to achieve this, three conditions must be fulfilled:

- Limit the voltage rise of the installation to voltage values that are tolerated by the equipment to be protected, by shunting the lightning current to the low-lying reference voltage (bonding and earthing systems): this is the role of voltage surge protectors.
- Avoid the appearance of dangerous overvoltages between the devices themselves and between the devices, protection circuits and the various exposed metal conductive parts: this is the role of the equipotential bonding system.
- Minimise the effects of induction due to the fields generated by the lightning strike itself and by the lightning conductor downconductors on all the conductive loops (electrical power and communication lines) and also the building structures. The appropriate location of the equipment and its wiring method can limit induced overvoltages.

2 LIGHTNING STRIKE WITHSTAND OF EQUIPMENT

Irrespective of how the energy of the lightning strike accesses the installation, it causes overvoltage and current values that are dependent on the structure of the installation and where the energy is generated. The need to protect equipment against overvoltages must be based on a comparison between the prospective value of the lightning strike according to the installation conditions (installation class) and the impulse voltage withstand value (overvoltage category) of the equipment in question (see tables on the opposite page).



Installation classes defined by standard IEC 61000-4-5

| Class | Max. impulse voltage | Installation conditions |
|-------|----------------------|---|
| 0 | 25 V | Well protected: all incoming conductors are equipped with voltage surge protectors, the equipment is connected to an bonding system subject to very little interference, and the electronic equipment has its own power supply. In general, special room or installation. |
| 1 | 500 V | Partly protected: conditions similar to class 0 but in which switching operations may cause overvoltages. |
| 2 | 1 kV | With separate wiring: the power supply is well separated from the other circuits, the bonding system of the power circuits is subject to interference from the installation or lightning. |
| 3 | 2 kV | With common wiring: the power and signal conductors run in parallel, the protected electronic equipment and electrical equipment are connected to the same power supply, and the bonding system is subject to considerable interference. |
| 4 | 4 kV | With interconnection via external cables and common wiring between power and signal conductors: the installation is connected to the bonding system of the power circuit, all circuits share the same power supply. |
| 5 | 4 kV ⁽¹⁾ | With connection to overhead lines: the electrical and electronic equipment is subject to line interference but the lines have primary protection. There is no bonding system or appropriate earthing device. |
| X | x kV | Specific conditions to be defined. |

(1) 6 kV recommended



Specified impulse withstand values for equipment on 230/400 V supply (standard IEC 60664-1)

| Overvoltage category | Type and characteristics of the equipment | Impulse voltage Uimp (kV) |
|----------------------|---|---------------------------|
| IV | Equipment installed upstream of the distribution panel: meters, gauge, fuse carrier and main circuit-breaker, etc. | 6 |
| III | Equipment forming part of the fixed installation: wiring accessories, circuit breakers, socket outlets, trunking, junction boxes, or permanently connected equipment for industrial use: motors, furnaces, etc. | 4 |
| II | Everyday equipment designed to be connected: domestic tools and appliances | 2.5 |
| I | Sensitive equipment with reduced withstand incorporating electronic circuits. Proximity or integrated protection may be advisable | 1.5 |



The stated lightning strike immunity of a component does not guarantee the immunity of the item of equipment in which it is integrated and makes no assumptions about its installation conditions. An overall view is therefore essential.

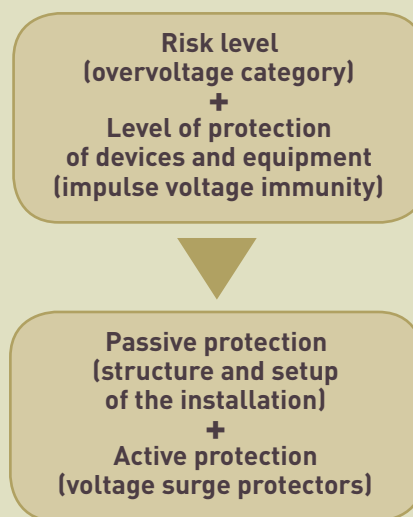

Protection against the effects of lightning (continued)

In order to carry out tests, the lightning strike is simulated by a special hybrid generator which generally provides a combined or composite signal, voltage 1.2/50 μs and current 8/20 μs (class II voltage surge protector), according to the definition in standard IEC 60060-1.

The first number designates the rise time (duration of the front) and the second designates the time it takes the signal to return to half value (see opposite page). The 10/350 μs current wave is used for class I high energy voltage surge protectors designed to protect against voltage feedback due to the presence of a lightning conductor. The 10/700 (CCITT) voltage wave is applied for lines and access points on long distance telecommunications circuits (telephone system and ELV).

3 PASSIVE PROTECTION

Protection comes from the structure and setup of the installation. This refers to:

- Equipotentiality, which is created by the bonding system, for which four levels are suggested (see the book 08 "Protection against external disturbances")
- Electrical separation of power supplies between the so-called "sensitive" circuits and the power circuits (see the book 08 "Protection against external disturbances")
- Geometric separation of circuits intended to limit crosstalk couplings between the conductors of these circuits (see the book 08 "Protection against external disturbances"). NB: The existence of coupling loops sensitive to the electromagnetic field generated by lightning is based on dimensional aspects (area of the loop subjected to the field) and geometric aspects (routes of the conductors), and must therefore be distinguished from the concept of cohabitation distance between the conductors themselves (separation distance).
- Earthing electrode schemes (or earthing systems), the type of which affects the behaviour of the installation (see the book 03 "Electrical energy supply") and consequently the choice of voltage surge protectors.

Standard wave

A standard impulse voltage wave (called 1.2/50 wave) is applied to the equipment to characterise and qualify its withstand to overvoltages caused by lightning in installations.

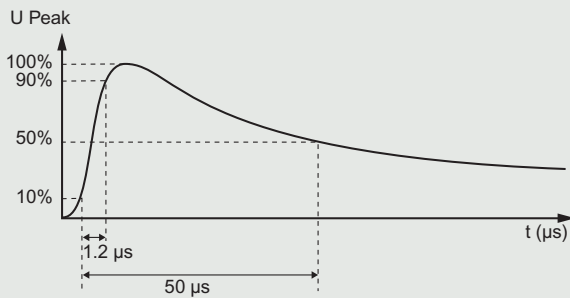

A current wave with a similar waveform is superimposed over this wave, but it is out of phase and has a 8/20 μs characteristic.



There is always some risk connected with the indirect effects of lightning. The additional cost of protection devices, compared to the potential losses, is negligible and pays for itself when the first incident happens. But voltage surge protectors are not a cure-all if they are used in a badly designed installation. It is above all through the precautions taken in the installation's structure and setup (passive protection) that the best protection will be established.

Passive protection: structure and setup of the installation

Passive protection is defined by interdependent concepts, for some of which it is sometimes difficult to estimate the qualitative value with precision: scale of the installation, separation of circuits, level of equipotentiality. The logic diagram below should therefore be used as an indicator of the level of passive protection:

- Good when a maximum number of criteria are in the green zone
- Poor when the majority are in the red
- Average in intermediate situations (orange levels or green and red levels present together, for example TN earthing system but very large site).

This provides a quick, overall, visual assessment. However, a full, in-depth analysis in accordance with standard IEC 62305-4 is strongly recommended for large-scale installations such as industry, or large office or commercial complexes (see below).

Equipment installation class (lightning impulse voltage)

| | | | |
|------|------|--------|--------|
| 6 kV | 4 kV | 2.5 kV | 1.5 kV |
|------|------|--------|--------|

Earthing system

| | | |
|----|----|----|
| TT | IT | TN |
|----|----|----|

Scale of the installation (number of loops)

| | | |
|-------------------|------------------------|---------------|
| very large (site) | large (block of flats) | small (house) |
|-------------------|------------------------|---------------|

Geometric separation of circuits

| | | |
|-------------------------|----------|------------------------------|
| not separate (coupling) | separate | shielded (not much coupling) |
|-------------------------|----------|------------------------------|

Separation of the power supply for sensitive circuits

| | | |
|-------------------|-----------------------|-----------------|
| same power supply | separate power supply | separate source |
|-------------------|-----------------------|-----------------|

Level of equipotentiality

| | | | | |
|----------------------------|--------------------------|--------------------------|------------------------|--------------------|
| 0 protective conductors | 1 earthing conductors | 2 equipotential links | 3 meshing of blocks | 4 total meshing |
|----------------------------|--------------------------|--------------------------|------------------------|--------------------|



Standard IEC 62305-4 proposes an analytical approach to the risks of damage to electrical and electronic equipment caused by lightning. This specific approach is justified by the increased sensitivity of equipment, its ever-increasing density and the particular modes of propagation specific to modern buildings (height above ground level, reinforcement of concrete, numerous access routes via all types of networks entering and running through buildings). Galvanic (common impedance) coupling and magnetic coupling (as a result of radiated fields) will carry interference from lightning throughout the building with the risk of significant damage. In total agreement with the concept of passive protection described on the previous page, standard IEC 62305-4 defines protected zones and their protection levels (LPZ1, LPZ2, etc.). It uses the concepts of single earthing electrode, equipotential bonding system, connection of these systems, and shielding of lines. The advantage is above all the systems analysis that it proposed, which is applicable to existing as well as new systems, providing forms for inspection and maintenance. Application of the earth implementation rules specified by this standard will significantly reduce internal overvoltages. However, it should be remembered that it also explains very clearly, with supporting calculations, that it is necessary to use voltage surge protectors in each consumer unit and near equipment in order to really provide total protection of the installation. This document also reminds users of the integral link between aspects of the building and the installation (passive protection) and protection by voltage surge protectors (active protection).

Protection against the effects of lightning (continued)

4 GENERAL ARCHITECTURE OF THE BONDING SYSTEM

The outline diagram opposite shows the general architecture of an installation, its physical levels between the power supply and the application and the various links to the protective conductors, the exposed conductive parts and the earth. The number of distribution levels has been limited to 3. In practice a larger number may be observed, but the principle remains the same.

It must be remembered that this architecture does not differ fundamentally between a very high power installation (industry) and a low power installation (domestic). It is simply the scale and number of distribution levels that differ, with a domestic installation being reduced to a single level. The connection level designates both the HV (green tariff) and the LV (blue or yellow tariff) connections, but it only refers in fact to a legal limit of ownership that does not alter the basic electrical diagram. However the risk of lightning on the LV link between the transformer and the main distribution level may be very different, depending on the nature of this link:

- Conductors several hundred metres long, sometimes overhead, for public distribution
- Short conductors, usually protected by buildings, in industry or large commercial installations.

This diagram shows the multiplicity of links with earth and therefore voltage feedback points due to lightning, the risk of which is increased by the presence of lightning conductors. The positioning of voltage surge protectors at all levels in the installation is therefore even more strongly recommended.

These links are above all intentional (equipotentiality of panels, circuits for protection of people against indirect contact), and concern both terminal circuits (sockets) and circuits in which the receiver is continuously connected.

Depending on the activity (EMC sensitivity) and the quality or age of the installation, the local equipotential links (solid green line on the diagram) between each distribution board and the surrounding local exposed conductive parts are implemented to a greater or lesser degree. But although they may be systematically implemented at main distribution level, this is more rarely the case at terminal distribution level.

It must be remembered that these links, which are essential in terms of EMC, are in addition to the protective conductors. Under no circumstances can they take the place of the protective conductors (See the book 08 "Protection against external disturbances). In addition to these intentional links, there are very often "unintentional" links, which are of varying quality but nonetheless very real: by the very contact of devices with the ground, via their fixing, by their physical location (for example on the machine frame), as well as via the shielding of data conductors (computing), or the exposed conductive parts (0 potential) of electronic equipment.

In practice there are therefore countless entry points for overvoltages and feedback from earth, especially when installations are spread over a wide area. In some cases, lightning conductors can protect buildings which are located electrically on a secondary distribution level. The overvoltage that they create at local ground level would therefore be even more likely to spread to the terminal circuits.



Load circuits (sockets, proximity panels, direct applications) can be supplied directly from the main LV distribution board. These circuits and their devices are therefore subject to more restrictive conditions (Isc, Uimp) than they would be at terminal distribution level. They must therefore be protected accordingly.

Positioning of voltage surge protectors in an industrial or commercial installation

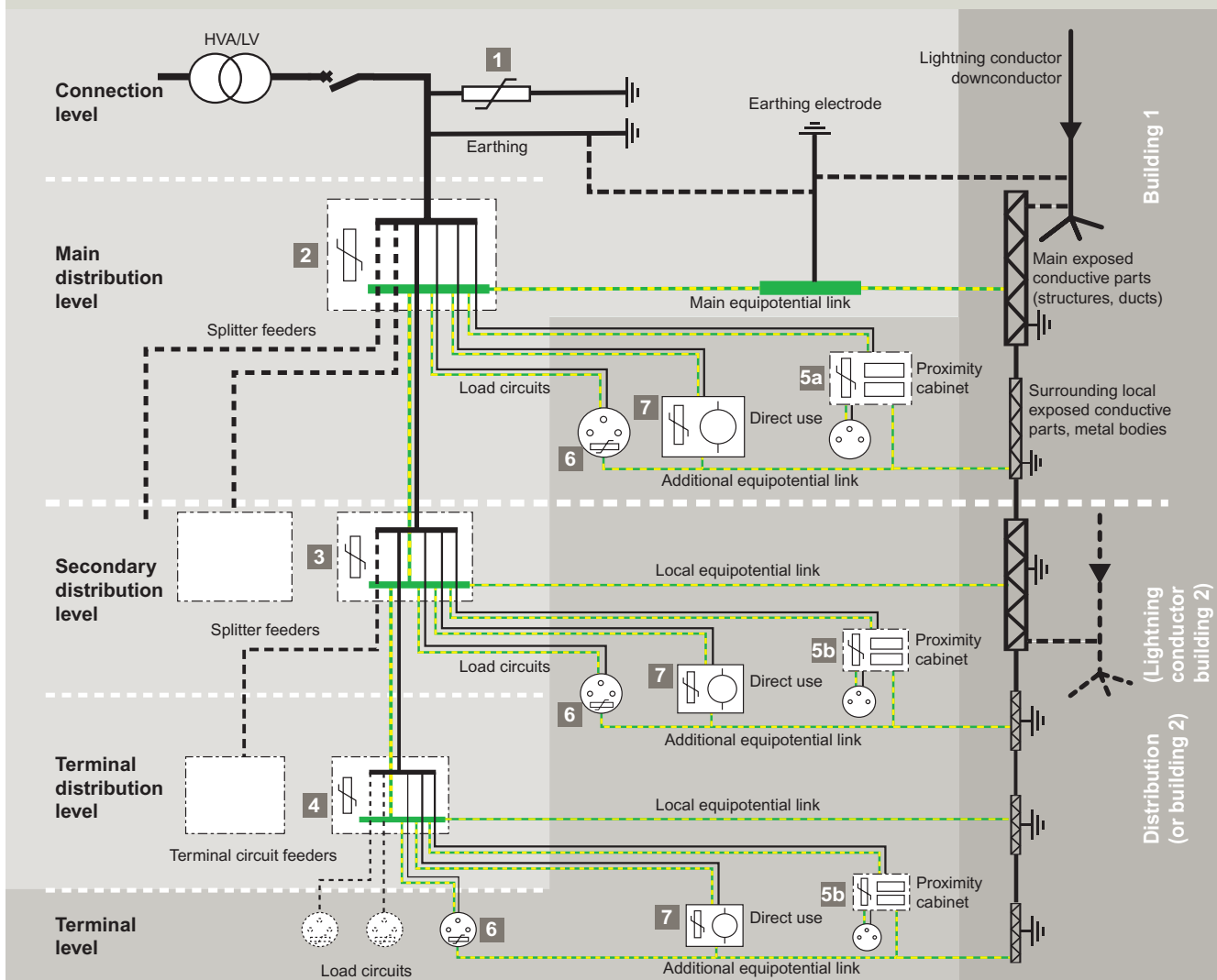

| Type of voltage surge protector | Location of the voltage surge protector | | | |
|--|---|-----------------------------|---------------------------|-----------------------------|
| | 1 single building | | 2 buildings | |
| | with lightning conductors | without lightning conductor | with lightning conductors | without lightning conductor |
| Class I Iimp = 25 kA (increased lightning capacity E) | 1 or 2 ⁽¹⁾ | - | 1 or 2 ⁽¹⁾ , 3 | - |
| Class II I _{max} = 70 kA (high capacity H) | - | 2 | - | 2 |
| Class II I _{max} = 40 kA (increased capacity E) | 3, 5a | 3, 5a | 4, 5a | 3, 5a |
| Class II I _{max} = 15 kA (standard capacity S) | 4, 5b | 4, 5b | 5b | 4, 5b |
| Proximity voltage surge protector ⁽²⁾ on terminals P | | | 6 | |
| Optional voltage surge protector incorporated in the receiver | | | 7 | |

(1) Installations with dedicated transformer room outside the main building with main LV distribution board: class I voltage surge protector installed in transformer room (1) and class II capacity H voltage surge protector in main LV distribution board (2)

(2) depending on the sensitivity of receivers

Voltage surge protectors

Voltage surge protectors are an essential element in the protection of modern installations, but choosing the right one and ensuring compliance with their installation rules are essential conditions for their effectiveness.

OPERATING PRINCIPLE

The protection of internal networks (electrical, low current) and equipment against transient overvoltages is based on the use of voltage surge protectors, and consists principally of:

- Stopping the destructive energy as far upstream as possible of the equipment by giving it a special route to earth
- Preventing the appearance of destructive overvoltages on equipment by limiting them to levels that are compatible with the equipment
- Minimising the effects of induction due to the fields generated by the flow of lightning currents (see p. 07: active protection and passive protection of networks and equipment).

In the case of electrical systems, voltage surge protectors are generally installed in tap-off configuration (in parallel) between the live conductors and the earth (see diagram below). The operating principle of voltage surge protectors can be likened to that of a circuit breaker:

- In normal use (no overvoltage): the voltage surge protector is similar to an open circuit breaker
- When there is an overvoltage, the voltage surge protector becomes active and discharges the lightning current to earth. It can be likened to the closing of a circuit breaker which would short-circuit the electrical

network with the earth via the equipotential earthing system and the exposed conductive parts for a very brief instant, limited to the duration of the overvoltage. For the user, the operation of the voltage surge protector is totally transparent as it only lasts a tiny fraction of a second.

- When the overvoltage has been discharged, the voltage surge protector automatically returns to its normal state (circuit breaker open).



Many different English terms are used around the world to designate devices dedicated to protection against transient overvoltages with atmospheric origins or due to switching:

- Surge protective devices (SPD) being the only official term according to IEC standards and also for the new version of UL documents (UL 1449 edition 3)

- For Legrand: voltage surge protectors.

Other terms may be found referring to the same kind of devices, such as : lightning arresters, surge suppressors, overvoltage suppressors, overvoltage arresters, transient voltage limiters, etc.

Based on UL and IEEE standards, the term "Transient voltage surge suppressor" (TVSS) may also be found (official designation in UL 1449 edition 2 and IEEE standards).

It should be remembered that all these designations refer to devices intended for protecting electrical and electronic devices against "surges" (transient overvoltages). Overall protection of an installation is based on the protection of both the building itself (external protection of the building against direct lightning strikes) and the so-called internal "services" as designated by IEC 62305 (i.e. electrical and electronic equipment). These IEC documents use the term "lightning protection system" (LPS) for this and usually always recommend the use of SPDs (SPDs required when the building is protected against direct lightning strikes with lightning rods (also called lightning conductors, lightning arresters).

Voltage surge protectors for electrical networks

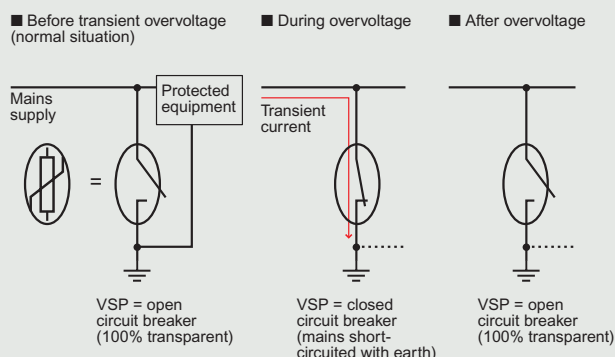

MAIN TECHNOLOGIES AND CHARACTERISTICS

Voltage surge protectors are mainly based on the use of 3 types of component. They have very high resistance under normal conditions (no over-voltage). As soon as an overvoltage appears, their resistance is virtually zero, causing short-circuiting of the supply with the earth.

1 AIR SPARK GAP, SURFACE DISCHARGE OR GAS DISCHARGE TUBE VOLTAGE SURGE PROTECTORS

These can shunt high energies and induce a low stray capacitance, but their response conditions are variable (atmospheric conditions, type of wave), and their follower current is high. They are generally used on power supplies.

2 VOLTAGE SURGE PROTECTORS WITH VARISTOR

The varistor is a zinc oxide (ZnO) based component that has the property of being extremely "non-linear". This means that at normal operating voltage the resistance of the component is very high and the leakage current is very low (< 1 mA). When an overvoltage appears, the resistance value drops sharply and a large part of the current is shunted, thus limiting the overvoltage downstream of the voltage surge protector. After a number of lightning strikes the varistor ages and must be replaced. Other voltage surge protector technologies are also available.

3 VOLTAGE SURGE PROTECTORS WITH SILICON COMPONENTS (ZENER DIODES, THYRISTOR, ETC.)

These are used at low voltage, on low level lines or in electronics. Their response time is excellent, but their discharge capacity is limited. They provide excellent protection in addition to voltage surge protectors with varistor.

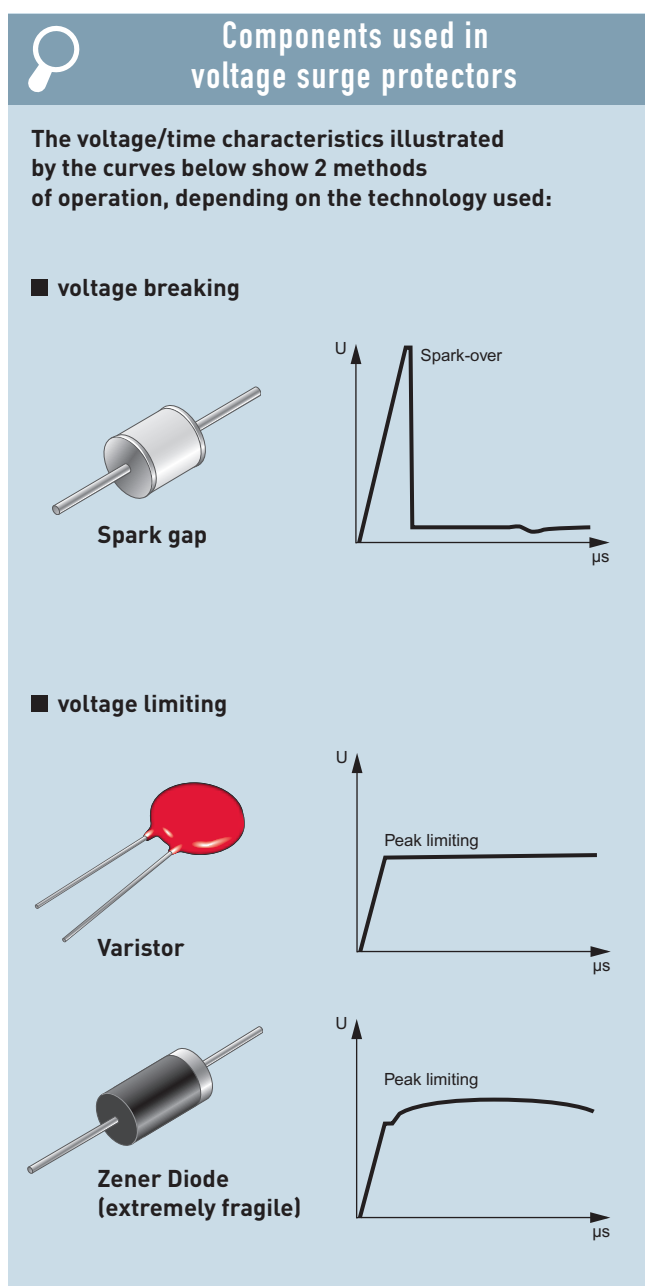

Voltage surge protectors (continued)

4 MAIN CHARACTERISTICS

Two concepts are essential in order to define the characteristics of a voltage surge protector:

- Its discharge capacity
- Its protection level

There are three main types of voltage surge protector:

• **Type 1 (class I):** Voltage surge protectors characterised by a discharge current with a conventional 10/350 waveform which is most similar to the current wave of direct lightning strikes on electrical networks or on lightning conductors.

These are voltage surge protectors with a high lightning energy discharge capacity and are usually used for buildings equipped with lightning conductors to reduce the difference in potential between the external

lightning protection system and the electrical installation while the lightning current is discharged to earth from the lightning conductor. Also used for highly critical installations (continuity of electrical supply).
Main characteristic: Iimp.

• **Type 2 (class II):** Voltage surge protectors for general applications characterised by a discharge current with a 8/20 waveform, which is the most similar conventional current waveform to the current waves caused by the indirect effects of lightning.
Main characteristics: I max and In.

• **Type 3 (class III):** Voltage surge protectors used for terminal protection, characterised by a combined wave (voltage 1.2/50; current 8/20) and by Uoc.



Characteristics of voltage surge protectors

■ **Nominal discharge current I_n**

Value of the discharge current (in kA) used for tests that the voltage surge protector must be able to discharge 15 times.

By analogy, can be compared with the rating of a circuit breaker, the rating being the nominal current that a circuit breaker can discharge continuously.

■ **Maximum discharge current I_{max} (Iimp)**

Current value in kA with 8/20 μ s waveform (10/350 μ s waveform for Iimp) that the voltage surge protector can discharge at least once. Also more commonly referred to as the lightning discharge capacity.

By analogy, can be compared to the breaking capacity of a circuit breaker.

■ **Maximum steady state voltage U_c (in V)**

Specified maximum operating voltage of the voltage surge protector. This must be at least 110% of the nominal voltage U_0 of the supply (> 253 V for TT and TN earthing systems, 440 V for IT systems)

■ **Permanent operating current I_c**

Value (in mA) of the current that is discharged in the voltage surge protector at its voltage U_c when there is no fault. Incorrectly named leakage current.

■ **Protection level U_p expressed in kV**

Value characterising the level to which the overvoltage is reduced during the discharge of the nominal discharge current I_n , for example: 1 - 1.2 - 1.5 - 1.8 - 2 - 2.5 kV.

■ **Residual voltage U_{res}**

Voltage value measured at the voltage surge protector terminals when it is subjected to any discharge current I . For any current value below the nominal current I_n , this value must never exceed that of U_p .

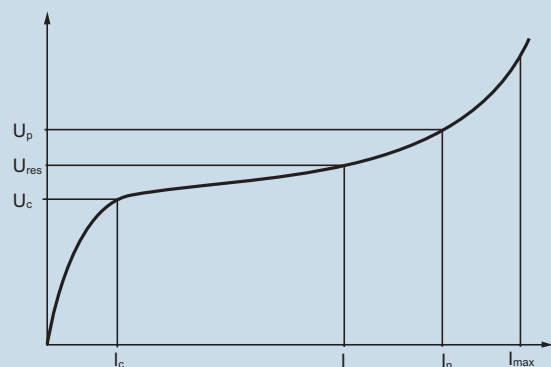

▲ Typical curve of a varistor and main characteristics

PROTECTION PRINCIPLE

1 PROTECTION MODES

There are two lightning overvoltage modes:

- Common mode
- Residual current mode

Lightning overvoltages appear mainly in common mode and usually at the origin of the electrical installation.

Overtages in residual current mode usually appear in TT mode and mainly affect sensitive equipment (electronic equipment, computers, etc.).

Phase/neutral protection in a TT earthing system is justified when the neutral on the distributor side is linked to a connection with a low value (a few ohms whereas the installation's earthing electrode is several tens of ohms).

The current return circuit is then likely to be via the installation neutral rather than the earth.

The residual current mode voltage U , between phase and neutral, can increase up to a value equal to the sum of the residual voltages of each element of the voltage surge protector, i.e. double the level of protection in common mode.

Common mode protection between phase/neutral and earth

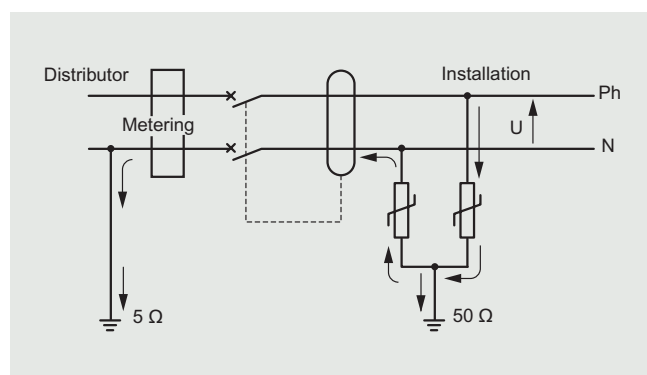
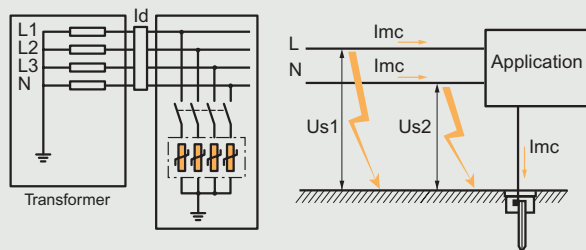

Residual current mode protection between phase and neutral

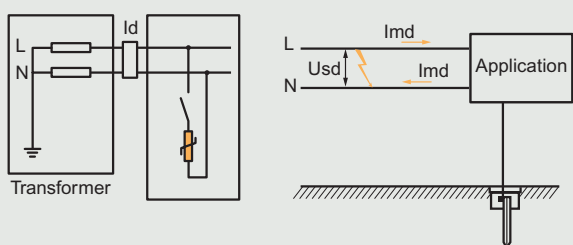

A similar phenomenon may occur in a TN-S earthing system if both the N and PE conductors are separate or not properly equipotential. The current is then likely to follow the neutral conductor on its return rather than the protective conductor and the bonding system. A theoretical optimum protection model, which applies to all earthing systems, can be defined, although in fact voltage surge protectors nearly always combine common mode protection and residual current mode protection (except IT or TN-C models).



It is essential to check that the voltage surge protectors used are compatible with the earthing system. The compatible systems are given for each Legrand voltage surge protector.

Voltage surge protectors (continued)

2 CASCADED PROTECTION

Just as overcurrent protection must be provided by devices with ratings appropriate to each level of the installation (origin, secondary, terminal) coordinated with each other, protection against transient overvoltages is based on a similar approach using a "cascaded" combination of several voltage surge protectors. Two or three levels of voltage surge protectors are generally necessary to absorb the energy and limit overvoltages induced by coupling due to high frequency oscillation phenomena (see p 26: protected lengths).

The example below is based on the hypothesis in which only 80% of the energy is diverted to earth (80%: empirical value dependent on the type of voltage surge protector and the electrical installation, but always less than 100%).

The principle of cascaded protection is also used for low current applications (telephony, communication and data networks), combining the first two levels of protection in a single device that is usually located at the origin of the installation. Spark gap based components designed to discharge most of the energy to earth are combined with varistors or diodes that limit the voltages to levels compatible with the equipment to be protected. Terminal protection is generally combined with this origin protection. The terminal protection is close to the equipment, provided using proximity voltage surge protectors.

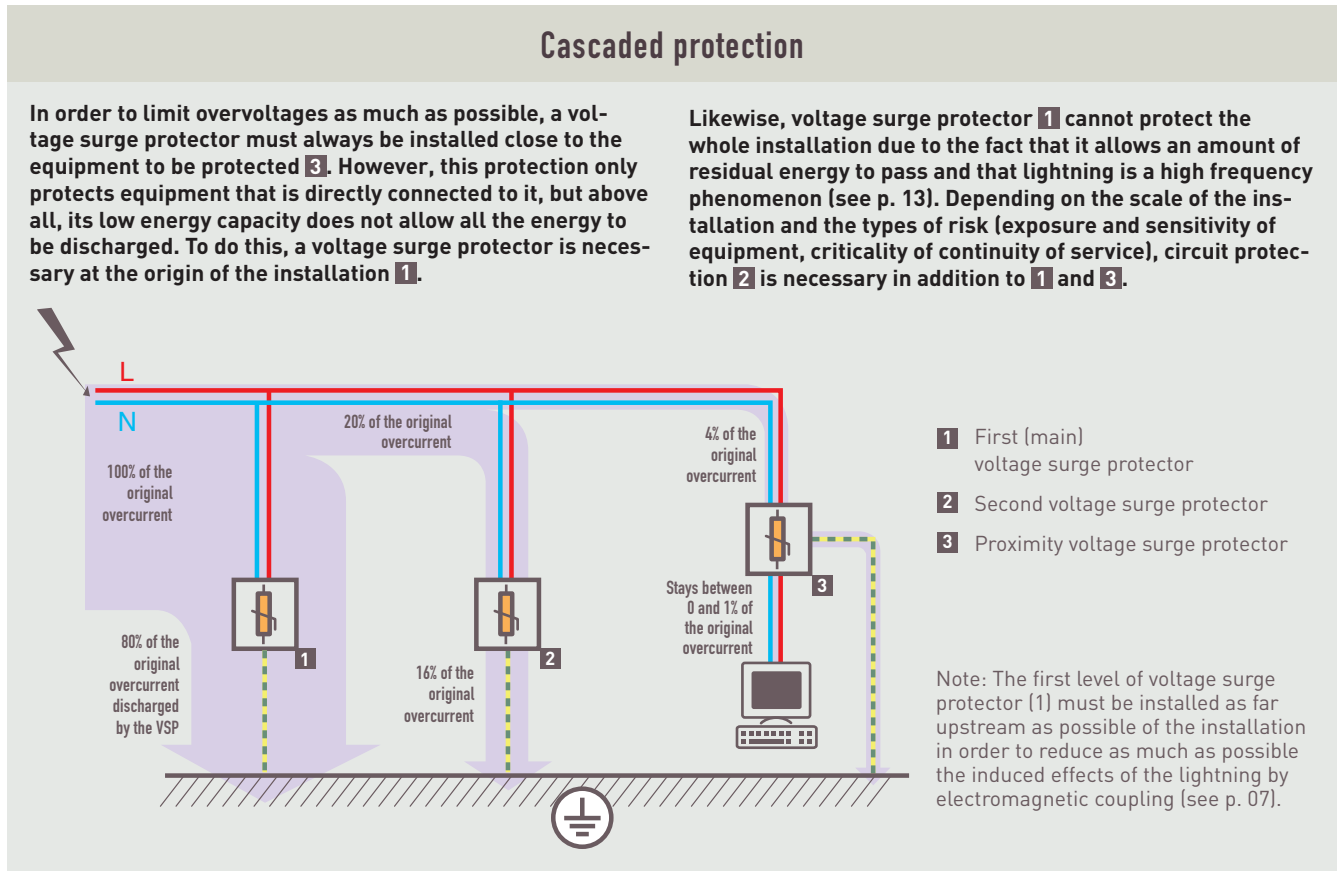

3 LOCATION OF VOLTAGE SURGE PROTECTORS

For effective protection using voltage surge protectors, it may be necessary to combine several voltage surge protectors:

- Main voltage surge protector ①
- Circuit voltage surge protector ②
- Proximity voltage surge protector ③

Additional protection may be necessary depending on the scale (line lengths) and the sensitivity of the equipment to be protected (computing, electronic, etc.). If several voltage surge protectors are installed, very precise coordination rules must be applied (see page 28).

On the following pages Legrand offers a simple method of defining the voltage surge protectors to be provided and their location, based on the estimation of the risk of lightning and its consequences.



It is important to keep in mind that the protection of the overall installation and equipment is only fully effective if:

- Multiple levels of VSPs are installed (cascading) to ensure the protection of equipment located some distance from the origin of the installation: required for equipment located 30 m or more away (IEC 61643-12) or required if the protection level Up of the main VSP is higher than the category of equipment (IEC 60364-4-443 and 62305-4 - see page 15)
- All networks are protected:
 - Power networks supplying the main building and also all secondary buildings, external lighting systems of car parks, etc.
 - Communication networks: incoming lines and lines between different buildings

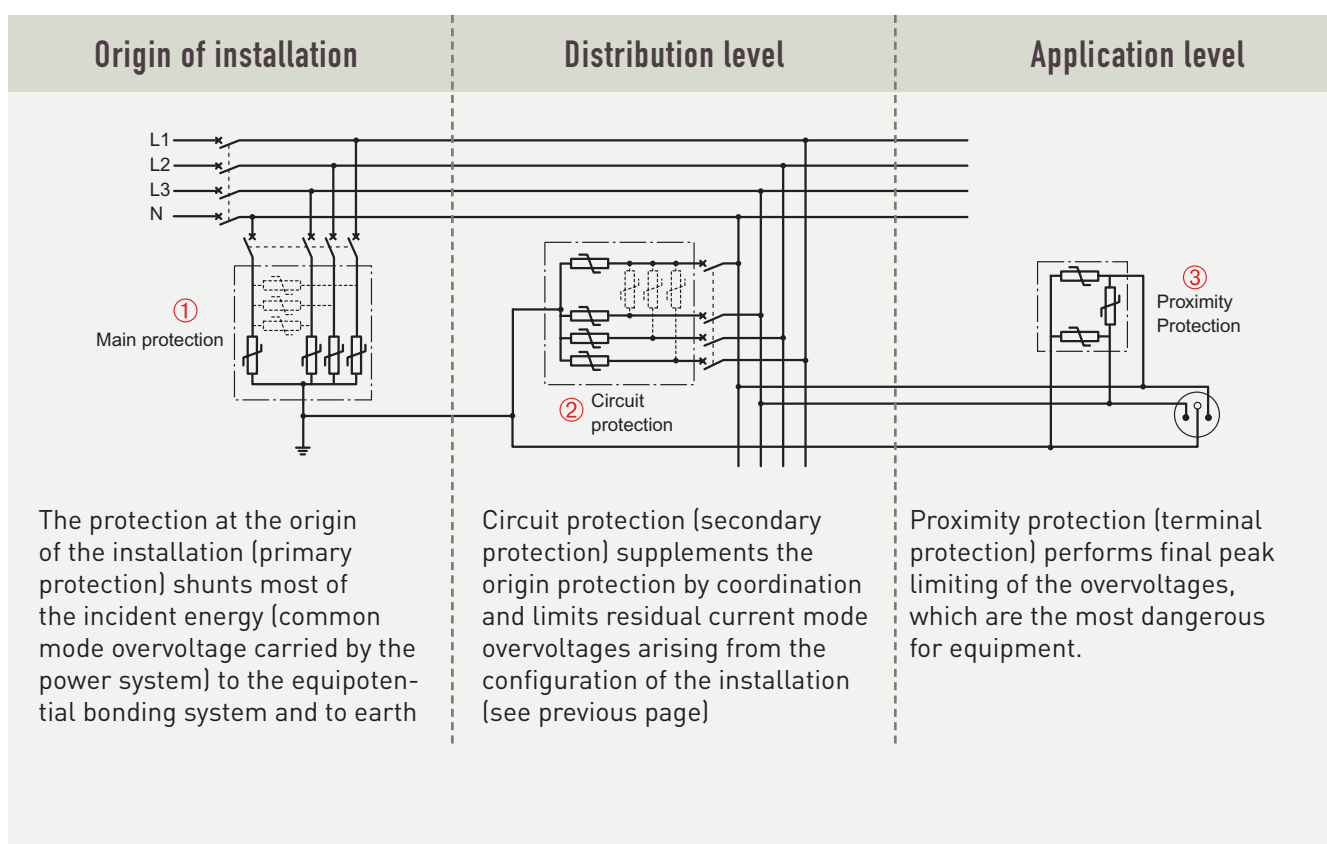

Voltage surge protectors (continued)

4 PROTECTED LENGTHS

It is essential that the design of an effective voltage surge protection system takes account of the length of the lines supplying the receivers to be protected (see table below).

In fact, above a certain length, the voltage applied to the receiver may, by means of a resonance phenomenon, considerably exceed the expected limiting voltage. The extent of this phenomenon is directly connected with the characteristics of the installation (conductors and bonding systems) and with the value of the current induced by the lightning discharge.



A VSP is correctly wired when:

- The protected equipment is equipotentially bonded to the same earth to which the VSP is connected
- The VSP and its associated backup protection (page 30) are connected:
 - To the network (live wires) and to the main protective bar (PE/PEN) of the board with conductor lengths as short as possible and less than 0.5 m (page 28)
 - With conductors whose cross-sections are appropriate for the VSP requirements (see table below).

| Maximum line length between voltage surge protector and device to be protected | | | | | |
|--|----------------------|---------------------------|-------------------------|-------------------------------|-------------------------|
| Voltage surge protector position | | at origin of installation | | not at origin of installation | |
| Conductor cross-section | | wiring (domestic) | large cables (industry) | wiring (domestic) | large cables (industry) |
| Composition of the bonding system | PE conductor | < 10 m | 10 m | < 10 m ⁽¹⁾ | 20 m ⁽¹⁾ |
| | meshed/equipotential | 10 m | 20 m | 20 m ⁽¹⁾ | 30 m ⁽¹⁾ |

(1) Protection recommended at the point of use if distance is greater



Above a certain length d , the circuit protected by the voltage surge protector will start resonating when the inductance and capacitance are equal:

$$L\omega = -\frac{1}{C\omega}$$

The circuit impedance is then reduced to its resistance.

Despite the part absorbed by the voltage surge protector, the residual lightning current I on the circuit is still impulse-based. Its increase, due to resonance, will result in significant increases in the U_d , U_c and U_{rm} voltages. Under these conditions, the voltage applied to the receiver can double.

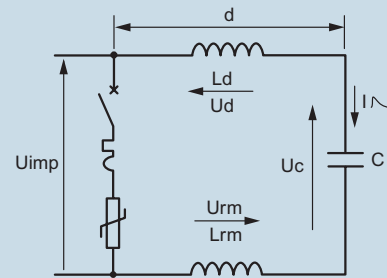

C : capacity representing the load
 L_d : power supply line inductance
 L_{rm} : bonding system inductance



The installation of voltage surge protectors must not adversely affect continuity of service, which would be contrary to the desired aim. They must be installed, in particular at the origin of domestic or similar installations (TT earthing systems), in conjunction with an S type delayed residual current device. Caution, if there are significant lightning strikes (> 5 kA), the secondary residual current devices may still trip.

INSTALLING VOLTAGE SURGE PROTECTORS

1 CONNECTING VOLTAGE SURGE PROTECTORS

1.1. Bonding system or earth connection

Standards bodies use the generic term “earthing device” to designate both the concept of bonding system and that of an earthing electrode, making no distinction between the two. Contrary to received opinion, there is no direct correlation between the value of the earthing electrode, provided at low frequency to ensure the safety of people, and the effectiveness of the protection provided by voltage surge protectors. As demonstrated below, this type of protection can be established even in the absence of an earthing electrode.

The impedance of the discharge circuit of the current shunted by the voltage surge protector can be broken down into two parts. The first, the earthing electrode, is formed by conductors, which are usually wires, and by the resis-

tance of the ground. Its essentially inductive nature means that its effectiveness decreases with the frequency, despite wiring precautions (limitation of length, 0.5 m rule, see p. 26). The second part of this impedance is less visible but essential at high frequency because it is in fact made up of the stray capacity between the installation and earth. Of course the relative values of each of these components vary according to the type and scale of the installation, the location of the voltage surge protector (main or proximity type) and according to the earthing electrode scheme (earthing system). However it has been proved that the voltage surge protector’s share of the discharge current can reach 50 to 90% on the equipotential system whereas the amount directly discharged by the earthing electrode is around 10 to 50%. The bonding system is essential to maintain a low reference voltage, which is more or less the same across the whole installation. The voltage surge protectors should be connected to this bonding system for maximum effectiveness.



The minimum recommended cross-section for the connection conductors takes account of the maximum discharge current value and the characteristics of the end of life protection device (see page 29). It is unrealistic to increase this cross-section to compensate for connection lengths that do not comply with the 0.5 m rule. In fact, at high frequency, the impedance of the conductors is directly connected to their length (see the book 08 “Protection against external disturbances”)

In power assemblies and large sized panels, it may be a good idea to reduce the impedance of the link by using the exposed metal conductive parts of the chassis, plates and enclosures.

Minimum cross-section of the voltage surge protector connection conductors

| Voltage surge protector capacity | | Cross-section (mm ²) |
|----------------------------------|---|----------------------------------|
| Class II VSP | S Standard: $I_{max} \leq 15 \text{ kA}$ (x 3-class II) | 6 |
| | E Increased: $I_{max} \leq 40 \text{ kA}$ (x 3-class II) | 10 |
| | H High: $I_{max} \leq 70 \text{ kA}$ (x 3-class II) | 16 |
| Class I VSP | | 16 |



The use of the exposed metal conductive parts of enclosures as protective conductors is permitted by standard IEC 60439-1 as long as this has been certified by the manufacturer. It is also possible for the connection of voltage surge protectors to the protection circuit (France: UTE C 15-443). However it is always preferable to retain a wire conductor for connecting the protective conductors to the terminal block or the collector, which then doubles the link made via the the exposed conductive parts of the enclosure chassis.

Voltage surge protectors (continued)

1.2. Connection length

In practice it is recommended that the total length of the voltage surge protector circuit does not exceed 50 cm. This requirement is not always easy to implement, but using the available exposed conductive parts nearby may help.

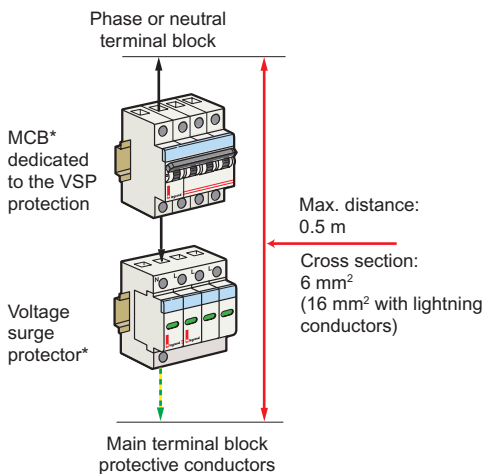

* may be installed on the same DIN rail. However the installation will be better protected if both devices are installed on 2 different DIN rails (VSP underneath the protection)



The number of lightning strikes that the voltage surge protector can absorb will decrease with the value of the discharge current (from 15 strikes for a current at value I_n to a single strike at I_{max}/I_{imp}).



Signalling auxiliaries Cat. Nos 039 56/57/58 are particularly recommended for industrial installations and office blocks. They simply clip on and are used for remote feedback on the status of class II voltage surge protectors (capacities H, E and S), via a changeover contact.



< Class I voltage surge protectors (capacity H and E) pre-equipped with a status feedback auxiliary.



0.5 m rule

In theory, when lightning strikes, the voltage U_t to which the receiver is subjected is the same as the protection voltage U_p of the voltage surge protector (for its I_n), but in practice the latter is higher. In fact, the voltage dips caused by the impedances of the voltage surge protector connection conductors and its protection device are added to this:

$$U_t = U_{I1} + U_d + U_{I2} + U_p + U_{I3}$$

For example, the voltage dip in 1 m of conductor travelled over by a 10 kA impulse current for 10 μ s will reach 1000 V

$$\Delta u = L \times \frac{di}{dt}$$

di: current variation 10,000 A

dt: time variation 10 μ s

L: inductance of 1 m of conductor = 1 μ s

Value Δu to be added to the voltage U_p

The total length L_t must therefore be as short as possible. In practice it is recommended that 0.5 m is not exceeded. In case of difficulty, it may be helpful to use wide, flat conductors (insulated braids, flexible insulated bars).

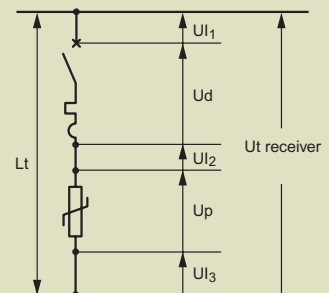



The continuity of the exposed conductive parts of Legrand XL³, Altis and Atlantic enclosures means that they can be used as PE conductors and also for connecting voltage surge protectors. It should also be noted that in addition to being easily accessible and allowing the 0.5 m rule to be adhered to, the exposed conductive parts of XL³ enclosures have a much lower high-frequency impedance (typical inductance < 0.01 $\mu\text{H}/\text{m}$) than that of a conductor. The use of exposed conductive parts for equipotential bonding purposes for voltage surge protectors must of course be accompanied by construction and installation precautions (see book 06 "Electrical hazards and protecting people").

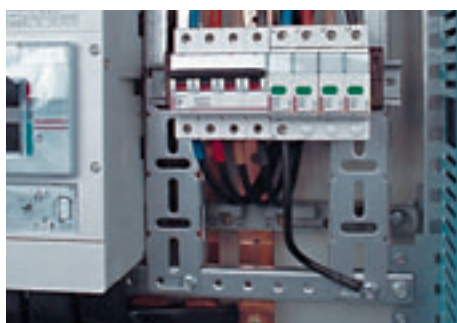

^ Increased capacity voltage surge protector (40 kA), at the origin of an industrial control system enclosure: the solid mounting plate (galvanised steel) provides the equipotential bonding and connection to earth



< To reduce the connection length, the associated protection is installed on the row above the voltage surge protector



The earth link conductor of the voltage surge protector should not be green/yellow in the sense of the definition of a PE conductor. Common practice is such that this marking is however frequently used.



< Using a Lexic distribution block enables easy connection of a voltage surge protector for protecting a group of circuits



Some wiring configurations can create couplings between the upstream and downstream conductors of the voltage surge protector, which are likely to cause the lightning wave to spread throughout the installation.

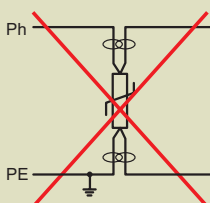

Upstream and downstream conductors connected on the voltage surge protector terminal with a common path.

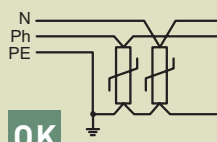

Input and output conductors physically well separated and connected on the same terminal.

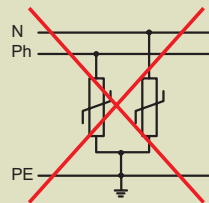

Connection conductors too long, output conductors physically separated.

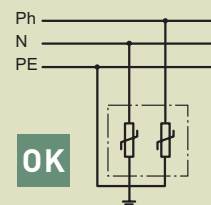

Connection conductors as short as possible with return conductor from the earth terminal close to the live conductors.

Voltage surge protectors (continued)

2 END OF LIFE PROTECTION OF VOLTAGE SURGE PROTECTORS

The voltage surge protector is a device whose end of life requires particular consideration. Its components age each time there is a lightning strike. At the end of life an internal device in the voltage surge protector

disconnects it from the supply; an indicator (on the protector) and an optional alarm feedback (status feedback accessory fitted) indicate this status, which requires replacement of the module concerned. If the voltage surge protector exceeds its limitation capacities, it may be destroyed by short-circuiting itself. A short-circuit and overload protection device must therefore be installed in series upstream of the voltage surge protector (this is commonly referred to the voltage surge protector branch).

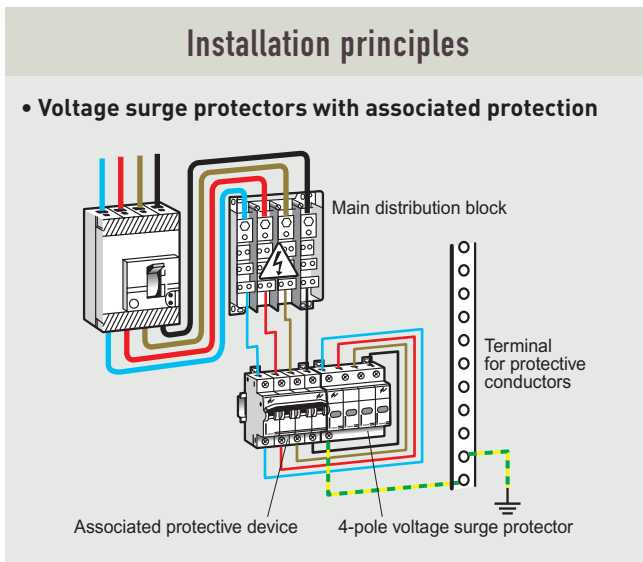

! Contrary to certain received opinion, a voltage surge protector must always be protected against possible short-circuit and overload currents. And this applies to all voltage surge protectors, both class II and class I, irrespective of the types of components or technologies used. This protection must be provided in accordance with the usual discrimination rules.

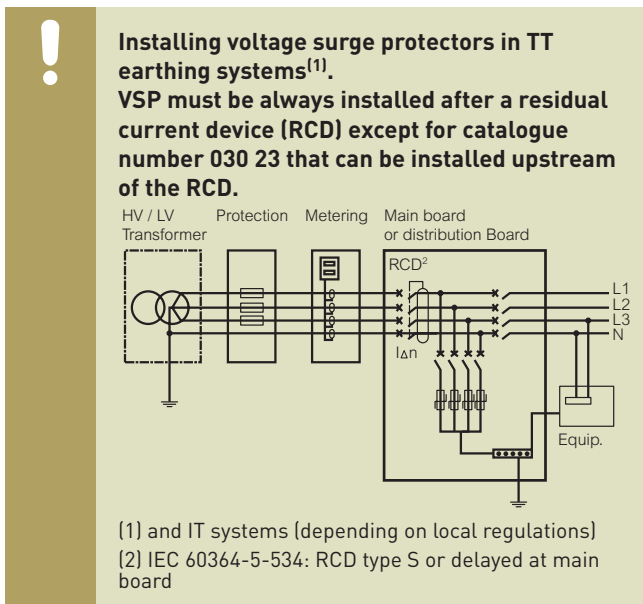

Associated protection devices (circuit breakers⁽¹⁾ or fuses⁽²⁾)

| Type of voltage surge protector | Earthing system | | |
|---------------------------------|-------------------|---------------|-------------------|
| | TT | TN | IT |
| Class I | Capacity H | gG 250 A max. | |
| | Capacity E | gG 250 A max. | NA ⁽³⁾ |
| | Capacity S | 40 A curve C | |
| Class II | Capacity H | 40 A curve C | |
| | Capacity E | 20 A curve C | |
| | Capacity S | 20 A curve C | 20 A curve C |

(1) DX, DX-H, DX-L (or similar) circuit breakers depending on the short-circuit current value at the installation point
(2) Fuses: see technical data sheets and installation guides (rating according to whether the short-circuit value at the installation point is less than or greater than 6 kA)
(3) Nul Applicable

➔ Voltage surge protectors for telephone lines p.36-37

3 COORDINATING VOLTAGE SURGE PROTECTORS

Arranging several voltage surge protectors in cascade requires them to be coordinated so that each of them absorbs the energy in an optimum way and limits the spreading of the lightning strike through the installation as much as possible. The coordination of voltage surge protectors is a complex concept which must form the subject of specific studies and tests. Minimum distances between voltage surge protectors or the insertion of decoupling chokes are not recommended by manufacturers.

Coordinating voltage surge protectors

Primary and secondary voltage surge protectors must be coordinated so that the total energy to be dissipated ($E_1 + E_2$) is shared between them according to their discharge capacity. The recommended distance d_1 enables the voltage surge protectors to be decoupled and thus prevents too much of the energy passing directly into the secondary voltage surge protector with the risk of destroying it. This is a situation which in fact depends on the characteristics of each of the voltage surge protectors. Two identical voltage surge protectors (for example U_p : 2 kV and I_{max} : 70 kA) can be installed without the distance d_1 being necessary: the energy will be shared more or less equally between the two voltage surge protectors. But two different voltage surge protectors (for example U_p : 2 kV/ I_{max} : 70 kA and U_p : 1.2 kV/ I_{max} : 15 kA) should be at least 8 m apart to avoid too much demand being placed on the second voltage surge protector.

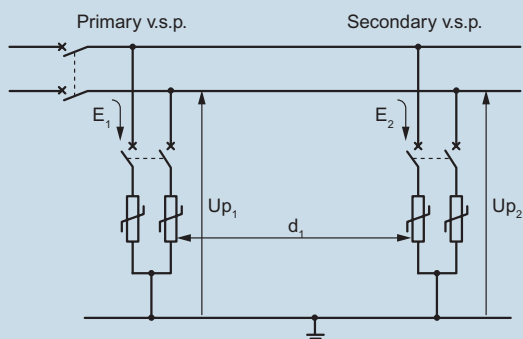

If not indicated, take $d_{1 \min}$ (in metres) as being 1% of the difference between U_{p1} and U_{p2} (in volts).

For example:

$U_{p1} = 2.0 \text{ kV (2000 V)}$ and $U_{p2} = 1.2 \text{ kV (1200 V)}$
 $\rightarrow d_1 = 8 \text{ m min. (2000 - 1200 = 800 } \gg 1\% \text{ of } 800 = 8 \text{ m)}$

Another example, if:

$U_{p1} = 1.4 \text{ kV}$ and $U_{p2} = 1.2 \text{ kV} \rightarrow d_1 = 2 \text{ m min.}$



< Legrand coordination modules Cat. Nos 039 62/63 are used to coordinate two voltage surge protectors in the same panel (up to 63 A), without taking account of the distances between them. It is necessary to install 1 module per live conductor in the circuit to be protected (including neutral conductor)



With the new class I voltage surge protectors, class II capacity E voltage surge protectors can be installed in the same panel without adding coordination modules

Minimum distances between voltage surge protectors

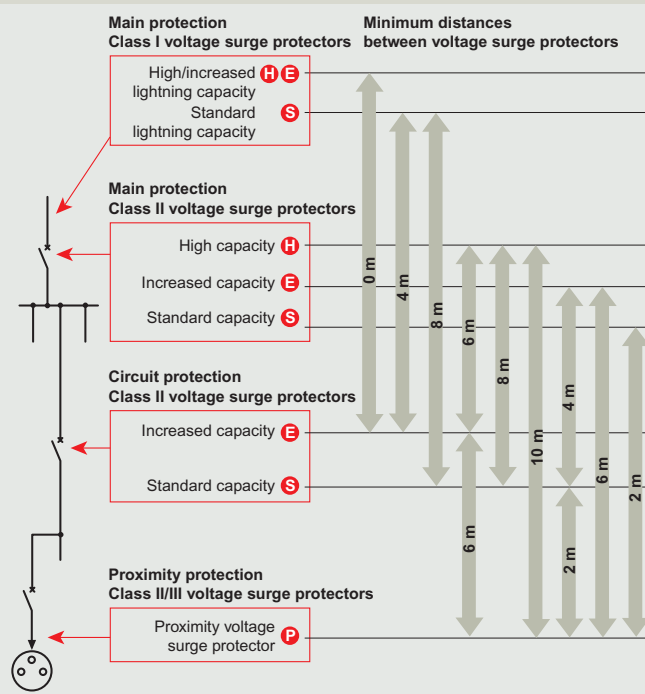

Voltage surge protectors (continued)

SELECTING VOLTAGE SURGE PROTECTORS

Selection principles:

- A class I (type I) protection device is compulsory at the origin of the installation and secondary buildings when a lightning conductor is present
- When there is no lightning conductor, a high capacity protection device (H voltage surge protector) for industrial installations and office complexes or an increased capacity protection device (E voltage surge protector) for smaller installations is recommended at the origin of the installation
- An increased capacity protection device (if an H main voltage surge protector is used) or standard capacity protection device (if an E main voltage surge protector is used) must be coordinated with the main protection device
- A proximity protection device (P voltage surge protector) is always recommended for very sensitive equipment (computer, electronic equipment).



Irrespective of the type of installation, the use of proximity voltage surge protectors must always be accompanied by a main voltage surge protector.

Based on the risk analysis and the requirements in the standards, the voltage surge protector selection chart on page 32 can be used to directly determine the catalogue numbers of the appropriate voltage surge protectors and the associated disconnectors (fuse or circuit breaker type protection devices upstream of the class I voltage surge protector: see page 29). For large size installations, the recommended type of protection can be determined using the procedure described on page 31. It is based on estimating the risk of lightning to the installation according to its location and type. It is then possible to determine the types of voltage surge protector recommended for panels, distribution circuits and near sensitive equipment. A full analysis can also be carried out in accordance with standard IEC 62305-2.



The protection at the origin of the installation can shunt most of the energy on its own, but it is not adequate to protect the whole installation and in particular sensitive equipment, for which a proximity protection device is necessary (see page 36).



• When the building is not protected by a lightning conductor, it is compulsory to install a voltage surge protector in buildings supplied via overhead lines in geographical areas classified AQ2 in accordance with standard IEC 60364-5-534. This requirement for protection using voltage surge protectors is extended to all areas when installations house sensitive equipment: computer, electronic equipment, etc.

• When the building is protected by a lightning conductor, it is compulsory to install a class I voltage surge protector at the origin of the installation or, in buildings with a number of private parts (apartment blocks, etc.), a class II voltage surge protector at the origin of each part in accordance with standard NF C 15-100.



Voltage surge protector regulations

■ **Standard IEC 61643-1⁽¹⁾**

This characterises class I voltage surge protectors according to 10/350 µs wave and class II according to 8/20 µs wave.

■ **Standard IEC 60364 on electrical installations**

This requires (§ 443-3) the installation of voltage surge protectors in buildings:

- Equipped with a lightning conductor ⇒ class I
- Supplied via an overhead line in geographical areas classified AQ2 (areas with $N_k > 25$: see the map on page 33) ⇒ class I

When a voltage surge protector is installed on the power circuit, it is recommended that a voltage surge protector complying with standard IEC 61643-21 is installed on the communication circuits (telephone line) and data transmission circuits

■ **Standard IEC 61643-12**

This gives recommendations for selecting and installing voltage surge protectors. Example: protection recommended for buildings less than 500 m from buildings equipped with a lightning conductor.

(1) Respectively class I and II voltage surge protectors according to standard EN 61643-11

The estimation of the risk is based on the analysis of a number of criteria:

- The probability of lightning strike in the area
- The mode of propagation of the lightning strike
- The topography of the site
- The types of equipment to be protected and their sensitivity
- The cost of the consequences of non-availability of the equipment.

Based on a simple and realistic approach, the Legrand procedure described below is an easy method for determining the type of protection to provide for the installation.

The risk of lightning strike is described as :

- Standard (★)
- High (★★)
- Very high (★★★)

It is determined according to 2 criteria:

- The level of exposure of the site (defined using the lightning strike density map)
- The location of the installation: location of the building, type of power supply, presence of a lightning conductor.

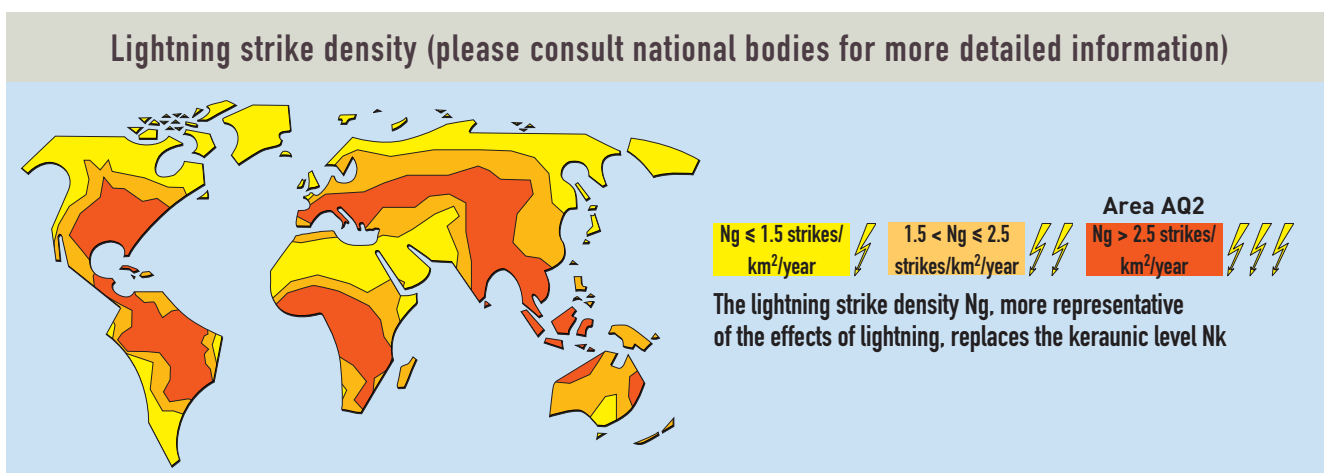





Risk level (the choice must be made according to the most restrictive criterion)

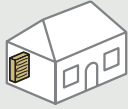
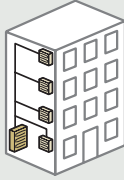

| Location of the installation | | Lightning strike density | | |
|--|--|---|---|---|
| | | $Ng < 1.5$ strikes/km ² /year ($Nk < 15$) | $1.5 < Ng \leq 2.5$ strikes/km ² /year ($15 \leq Nk \leq 25$) | $Ng > 2.5$ strikes/km ² /year ($Nk > 25$) |
| Location of the building | high density construction | | ★ | ★★ |
| | isolated construction | ★ | ★★ | ★★ |
| | mountainous area, near a body of water or a hill | ★★ | ★★★ | ★★★★ |
| Power supply | underground | | | ★ |
| | overhead ⁽¹⁾ | ★ | ★ | ★★ |
| | overhead at end of line ⁽¹⁾ | ★ | ★★ | ★★★ |
| Presence of a lightning conductor ⁽¹⁾ | | ★★★ | ★★★ | ★★★ |

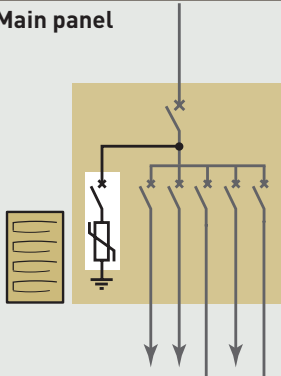
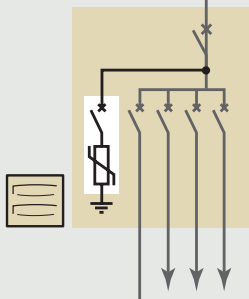
(1) ★ Protection by voltage surge protector compulsory in accordance with IEC 60364

Voltage surge protectors (continued)

| Select your V.S.P. and its associated protection | | | | | | | | | | |
|--|---|---------------|---------------|--|------------|---------------|--|--------|---------------|--------|
| Type of building |  Individual house | | |  Block of flats | | |  Small offices | | | |
| | Risk level (see p. 31) | high ★★ ★ | | | medium ★ ★ | | | low ★ | | |
| Power supply | 1P+N | 3P | 3P+N | 1P+N | 3P | 3P+N | 1P+N | 3P | 3P+N | |
| Main panel  | VSP | 2 x 039 10 | 3 x 039 10 | 4 x 039 10 | 039 31 | 039 32 | 039 33 | 039 41 | 3 x 039 40 | 039 43 |
| | Associated protection | 064 72 | 064 92 | 065 67 | 064 69 | 064 89 | 065 64 | 064 69 | 064 89 | 065 64 |
| + | | | | | | | | | | |
| Distribution panel  | VSP | 039 41 | 3 x 039 40 | 039 43 | 039 41 | 3 x 039 40 | 039 43 | 039 41 | 3 x 039 40 | 039 43 |
| | Associated protection | 064 69 | 064 89 | 065 64 | 064 69 | 064 89 | 065 64 | 064 69 | 064 89 | 065 64 |
| + | | | | | | | | | | |
| Proximity |  | | | Proximity VSP Celiane program Cat. No. 671 93 or Mosaic program Cat. No. 775 40 or Multi-outlet extensions Cat. Nos. 6946 40/42/44/51/56 | | | | | | |

| Office buildings | | Industry | | | |
|--|-----------------------|-----------------------|--------------------------|--------|--------|
| high ★★ ★ | | | medium ★★ ⁽³⁾ | | |
| 1P+N | 3P | 3P+N | 1P+N | 3P | 3P+N |
| - | 030 22 ⁽¹⁾ | 030 23 ⁽²⁾ | - | 039 22 | 039 23 |
| - | 3 x 174 65 | 4 x 174 65 | - | 071 33 | 071 48 |
| + | | | + | | |
| 039 31 | 039 32 | 039 33 | 039 31 | 039 32 | 039 33 |
| 069 21 | 069 41 | 070 01 | 069 21 | 069 41 | 070 01 |
| + | | | | | |
| Mosaic program Cat. No. 775 40 or Multi-outlet extensions Cat. Nos. 6946 40/42/44/51/56 | | | | | |

| IEC 60364-5-534: protection is mandatory | | |
|--|----------------|-------------------|
| Risk level | | |
|  (installation with external lightning protection) | ★★★ | |
|  (installation with overhead lines in AQ2 areas) | ★ | ★★ |
| | In urban areas | In isolated areas |

! The protection of an installation can only be guaranteed with several levels of voltage surge protectors cascaded together (see page 23).

(1) IT earthing system: 3 x 030 00 + 3 x 173 65 or 174 65
 (2) IT earthing system: 4 x 030 00 + 4 x 173 65 or 174 65
 (3) Large installations are always considered to have at least a medium risk level because of potential significant economic losses (production losses) (Installations with environmental risks → ★★ ★)

Voltage surge protectors (continued)

THE LEGRAND RANGE OF VOLTAGE SURGE PROTECTORS

1 CLASS I VOLTAGE SURGE PROTECTORS

The Legrand range of modular voltage surge protectors is divided into class I and class II, and into three levels linked to their discharge capacity. Class I voltage surge protectors are designed to protect the main panels of installations equipped with lightning conductors. However, H or E capacity class I voltage surge protectors are also recommended for protecting large size installations (industrial installations or office blocks) and in particular when there is a high service requirement (installations usually equipped with alternative energy sources such as generator sets, UPS, etc.) The use of S capacity class I voltage surge protectors is recommended for small residential or small business installations. They must all be installed with their associated protection devices (see page 30).



Class I voltage surge protectors are also required:

- In the presence of any metal item on the building that could act as a lightning conductor
- When the building is located less than 50 m from a tree or a building that is itself equipped with lightning conductors

Legrand also recommends class I voltage surge protectors when there have been previous lightning strikes.

| Other VSP classifications | | |
|---------------------------|--------------|---------------|
| EN 61643-11 | Type 1 (T1) | Type 2 (T2) |
| IEC 61643-1 | Class 1 (T1) | Class II (T2) |
| VDE 0675-6 ⁽¹⁾ | Class B | Class C |

(1) Old German standard for VSPs replaced by EN 61643-11

| The Legrand range of voltage surge protectors | | | | |
|---|----------------------------------|----------------------|--------------------------|--------|
| Types of voltage surge protector | Discharge capacity (Imax) | Nominal current (In) | Level of protection (Up) | |
|  <p>^ New class I voltage surge protectors specifically for protection at the origin of installations requiring a high service level</p> | High lightning capacity (H) | 50 kA | 1.5 kV | |
| | Increased lightning capacity (E) | 25 kA | 25 kA | 1.5 kV |
| | Standard lightning capacity (S) | 12.5 kA | 20 kA | 1.8 kV |

The discharge capacities and current values In are given for each protected pole

2 CLASS II VOLTAGE SURGE PROTECTORS

2.1. Proximity voltage surge protectors and those for communication networks

Class II voltage surge protectors can be installed at the origin of installations when the installation is not equipped with lightning conductors (external protection of the building against lightning) or at the distribution level of the installation.

Proximity voltage surge protectors are generally incorporated close to the products themselves: distribution block, wiring accessories, office modules, etc.



The electrical installation standard IEC 60364 and national equivalents (France: NF C 15-100) stipulate that at the origin of an installation supplied via the mains, the nominal current I_n must be at least 5 kA and the protection level $U_p \leq 2.5$ kV. More severe exposure or protection criteria may lead to more stringent requirements. Category I equipment must be protected with voltage surge protectors whose U_p value is less than 1500 V.

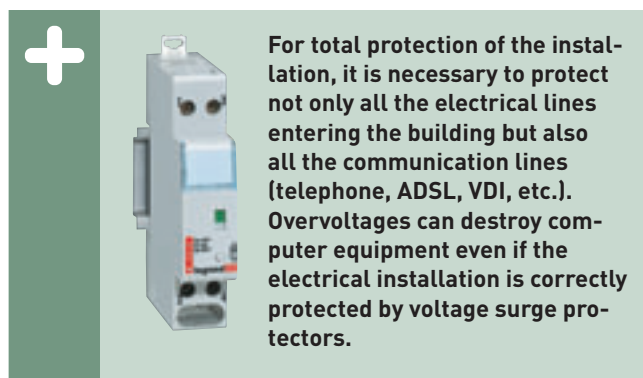
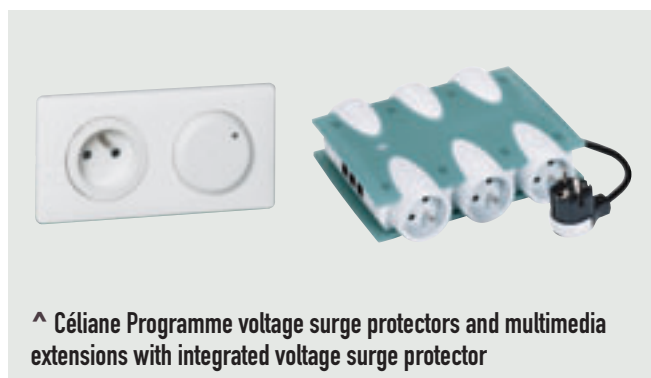

The Legrand range of voltage surge protectors

| Types of voltage surge protector | | Discharge capacity (I_{max}) | Nominal current (I_n) | Level of protection (U_p) |
|---|---------------------------------------|----------------------------------|----------------------------|-------------------------------|
| Lexic voltage surge protectors | High lightning capacity H | 70 kA | 20 kA | 2 kV |
| | Increased lightning capacity E | 40 kA | 15 kA | 1.4 to 1.8 kV ⁽¹⁾ |
| | Standard lightning capacity S | 15 kA | 5 kA | 1.8 kV |
| Proximity voltage surge protectors P | Mosaic wiring accessories | 3 kA | 1.5 kA | 1 kV |
| | Socket units | 1 to 8 kA ⁽¹⁾ | 1.5 to 3 kA ⁽¹⁾ | 1.2 kV |
| Lexic voltage surge protectors for telephone lines | | 10 kA | 5 kA | 100 or 260 V |

The discharge capacities and current values I_n are given for each protected pole (1) depending on the model

Voltage surge protectors (continued)

CHARACTERISTICS OF LEGRAND VOLTAGE SURGE PROTECTORS

1 MODULAR VOLTAGE SURGE PROTECTORS

Legrand modular voltage surge protectors are divided into three levels linked to their discharge capacity. They can be installed at the origin or at the distribution level of the installation.

| VSP for power lines | | | | | | | |
|---|------------------------------------|--------------------------------|-------------------------------|-----------------------|---------------------------------|-----------------------------------|-----------------------------------|
| | Type 1 VSP (class I) | | | Type 2 VSP (class II) | | | |
| | High lightning protection | Increased lightning protection | Standard lightning protection | High protection | Increased protection | Standard protection | |
| Cat. Nos | 030 00 | 030 22 | 030 23 | 039 10 | 039 20/21/22/23 | 039 30/31/32/33 | 039 40/41/43 |
| Mains supply | 230/400 V | 230/400 V | 230/400 V | 230/400 V | 230/400 V | 230/400 V | 230/400 V |
| Frequency | 50/60 Hz | 50/60 Hz | 50/60 Hz | 50/60 Hz | 50/60 Hz | 50/60 Hz | 50/60 Hz |
| Earthing system | TT-TN-IT | TNC | TT-TNS | TT-TN-IT | TT-TN-IT | TT-TN-IT | TT-TN |
| Protection mode | L(N)-PE | L-PEN | L-N/N-PE | L(N)-PE | L(N)-PE | L(N)-PE | L(N)-PE |
| Max. continuous operating voltage (Uc) | 440 V | 350 V | 350 V | 440 V | 440 V | 440 V | 320 V |
| Nominal discharge current In (8/20) | 50 kA | 25 kA | L-N: 25 kA N-PE: 100 kA | 20 kA | 20 kA | 15 kA | 5 kA |
| Max. discharge current | | | | | | | |
| I _{max} (8/20) | - | - | - | - | 70 kA | 40 kA | 15 kA |
| I _{imp} (10/350) | 50 kA | 25 kA | L-N: 25 kA N-PE: 100 kA | 12.5 kA | 10 kA | - | - |
| I _{total} (10/350) | - | 75 kA | 100 kA | - | - | - | - |
| Protection level (Up) | 1.5 kV | 1.5 kA | 1.5 kA | 1.8 kV | 2 kV at 20 kA 1.5 kV at 5 kA | 1.8 kV at 15 kA 1.3 kV at 5 kA | 1.4 kV at 15 kA 1.2 kV at 5 kA |
| Withstand to temporary overvoltages (Ut) | 440 V | 350 V | L-N: 335 V L-PE: 400 V | 440 V | 440 V | 440 V | 400 V |
| Associated protection | | | | | | | |
| gG fuse | max. 250 A | max. 250 A | max. 250 A | - | - | - | - |
| DX, DX-H, DX-L C curve | - | - | - | 40 A | 40 A | 20 A | 20 A |
| Leakage current at Uc (Ic) | - | - | - | < 1 mA | < 1 mA | < 1 mA | < 1 mA |
| Response time | 100 ns | 100 ns | 100 ns | 25 ns | 25 ns | 25 ns | 25 ns |
| Terminal capacity | | | | | | | |
| rigid conductor | 35 mm ² | 25 mm ² | 25 mm ² | 18 mm ² | 25 mm ² | 25 mm ² | 25 mm ² |
| flexible conductor | 50 mm ² | 35 mm ² | 35 mm ² | 25 mm ² | 16 mm ² | 16 mm ² | 16 mm ² |
| Degree of protection | IP 20 installation in an enclosure | | | | | | |
| Operating temperature | -10°C to + 40°C | | | | | | |
| Storage temperature | -20°C to + 70°C | | | | | | |

2 PROXIMITY VOLTAGE SURGE PROTECTORS

Maximum effectiveness of protection against overvoltages cannot be guaranteed with a single voltage surge protector. For this reason Legrand recommends

a combination of several cascaded voltage surge protectors with different protection levels, from the main panel through to the device to be protected (proximity protection of sensitive equipment). Maximum performance will then be achieved.

Main characteristics of proximity voltage surge protectors

| Cat. Nos | | 6946 40/42/44 | 6946 51/56 | 671 93 | 775 40 |
|---------------------|-------------------|---------------|------------|----------|----------|
| Uc | Md ⁽¹⁾ | 250 V AC | 250 V AC | 255 V AC | 255 V AC |
| | Mc ⁽²⁾ | 400 V AC | - | - | 255 V AC |
| I max | | 3 kA | 4 kA | 6 kA | 6 kA |
| In | | 1.5 kA | 2 kA | 1.5 kA | 1.5 kA |
| Level of protection | | | | | |
| Up | Md ⁽¹⁾ | 1 kV | 1 kV | 1 kV | 1 kV |
| | Mc ⁽²⁾ | 1.5 kV | - | - | 1 kV |
| Uoc | | 3 kV | 4 kV | 3 kV | 3 kV |

(1) Md: protection in difference mode [L-N]
 (2) Mc: protection in common mode [L-PE, N-PE]

+



< Proximity voltage surge protectors Cat. No. 671 93 (Céline programme) and Cat. No. 775 40 (Mosaic programme): voltage surge protection function directly integrated in the installation's sockets with replacement cassette for ease of maintenance



< Multimedia extensions with integrated voltage surge protector unit. Voltage surge protectors Cat. Nos 6946 40/42/44 incorporate dual protection: protection of the electrical network and protection of the communication network (telephony, ADSL), both of which are integrated in a cassette for ease of maintenance

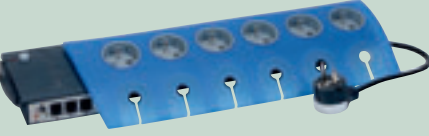

Voltage surge protectors (continued)

PROTECTION OF TELEPHONE LINES

When voltage surge protectors are installed on the low voltage network, it is advisable to add voltage surge protectors on the telecommunications and data transmission networks.

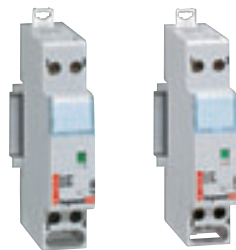

| Technical characteristics | | |
|------------------------------------|----------------------------|----------------|
| Cat. Nos | Analogue 038 28 | Digital 038 29 |
| Nominal voltage (Un) | 170 V | 48 V |
| Nominal discharge current (In) | 5 kA | |
| Maximum discharge current (Imax) | 10 kA | |
| Level of protection (Up) | 260 V | 100 V |
| Terminal capacity (flexible/rigid) | 0.5 to 2.5 mm ² | |
| Degree of protection | IP 20 | |
| Operating temperature | - 10°C to + 40°C | |
| Storage temperature | - 20°C to + 70°C | |



If electrical installations are referenced to a bonding system that is itself linked to a local earth, the telephone installations are generally referenced to a "distant earth" whose potential is not influenced by that of the "electrical earth".

During a lightning strike, an overvoltage will appear between the exposed conductive parts of the installation and the telephone line, creating danger for any telephone user. The risk exists irrespective of whether it is the telephone or power network that is hit by lightning.

The solution therefore consists in extreme cases of galvanically separating the telephone network (special translators) or more simply installing special voltage surge protectors whose earth terminal must be properly connected to the installation's bonding system.

Installation principles

■ Analogue connection with ITD (Internal Termination Device)

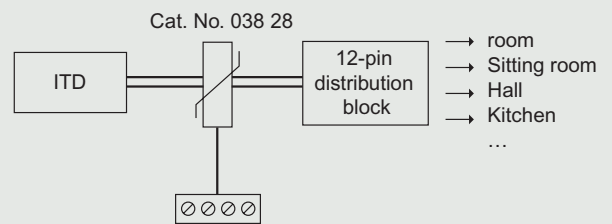

■ Analogue or digital connection with DNT (Digital Network Termination)

• Upstream protection

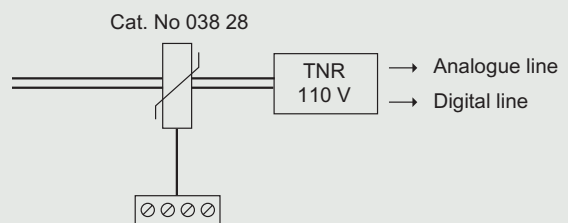

• Downstream protection

> Analogue or digital

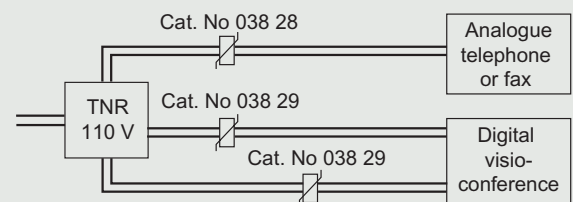

> Digital

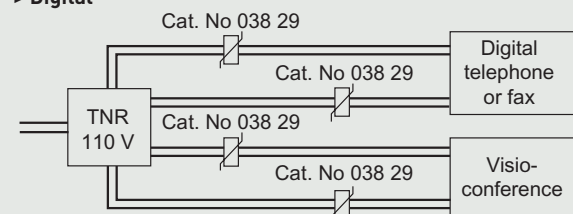

POWER GUIDE:

A complete set of technical documentation



01 | Sustainable development



08 | Protection against external disturbances



02 | Power balance and choice of power supply solutions



09 | Operating functions



03 | Electrical energy supply



10 | Enclosures and assembly certification



04 | Sizing conductors and selecting protection devices

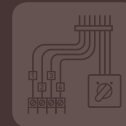

11 | Cabling components and control auxiliaries



05 | Breaking and protection devices

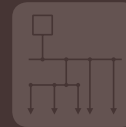

12 | Busbars and distribution



06 | Electrical hazards and protecting people



13 | Transport and distribution inside an installation



07 | Protection against lightning effects



Annexes
Glossary
Lexicon



World Headquarters and International Department
87045 Limoges Cedex - France
☎ : + 33 (0) 5 55 06 87 87
Fax : + 33 (0) 5 55 06 74 55